



TECHNICAL MEMORANDUM

Automatic Train Control: Concept of System

TM 3.3.1

Prepared by; Signed document on file 22 Jun 10
Ed Mortlock Date

Checked by; Signed document on file 22 Jun 10
Harvey Glickenstein Date

Approved by; Signed document on file 25 Jun 10
Ken Jong, PE, Engineering Manager Date

Released by; Signed document on file 28 Jun 10
Anthony Daniels, Program Director Date

Revision	Date	Description
0	25 Jun 10	Initial Release

Note: Signatures apply for the latest technical memorandum revision as noted above.

This document has been prepared by **Parsons Brinckerhoff** for the California High-Speed Rail Authority and for application to the California High-Speed Train Project. Any use of this document for purposes other than this Project, or the specific portion of the Project stated in the document, shall be at the sole risk of the user, and without liability to PB for any losses or injuries arising for such use.

System Level Technical and Integration Reviews

The purpose of the review is to ensure:

- Technical consistency and appropriateness
- Check for integration issues and conflicts

System level reviews are required for all technical memoranda. Technical Leads for each subsystem are responsible for completing the reviews in a timely manner and identifying appropriate senior staff to perform the review. Exemption to the system level technical and integration review by any subsystem must be approved by the Engineering Manager.

System Level Technical Reviews by Subsystem:

Systems;	<u>Signed document on file</u> Richard Schmedes	<u>20 Jun 10</u> Date
Infrastructure;	<u>Signed document on file</u> John Chirco	<u>16 Jun 10</u> Date
Operations;	<u>Signed document on file</u> Paul Mosier	<u>25 Jun 10</u> Date
Maintenance;	<u>Signed document on file</u> Paul Mosier	<u>25 Jun 10</u> Date
Rolling Stock;	<u>Terry Brunner</u>	<u>17 Jun 10</u> Date

Note; Signatures apply for the technical memorandum revision corresponding to revision number in header and as noted on cover.

3.4.3	DETERMINATION OF POSITION AND SPEED	25
3.4.4	HARDWARE REQUIREMENTS FOR VARIOUS SUBSYSTEMS	25
3.4.5	TYPES OF DATA TRANSMISSION FROM TRANSPONDERS	26
3.4.6	LOCATION OF ON-BOARD ATC EQUIPMENT	27
3.4.7	ATC SAFETY REQUIREMENTS	28
3.4.8	RELIABILITY, AVAILABILITY, AND MAINTAINABILITY OF THE ATC SYSTEM.....	28
3.4.9	DATA RADIO REQUIREMENTS	28
3.4.10	ATC REQUIREMENTS ON COMMON CORRIDORS	29
3.5	INTERFACES	29
3.5.1	ROLLING STOCK	29
3.5.2	COMMUNICATIONS	29
3.5.3	TRACTION POWER.....	30
3.5.4	OCS	30
3.5.5	TRACK.....	30
3.5.6	INFRASTRUCTURE.....	30
3.5.7	SYSTEM TIME	30
3.6	APPLICABILITY TO U.S. STANDARDS	30
4.0	SUMMARY AND RECOMMENDATIONS	31
5.0	SOURCE INFORMATION AND REFERENCES.....	32
6.0	DESIGN MANUAL CRITERIA	33
6.1	INFORMATION FOR INCLUSION IN DESIGN MANUAL.....	33
6.2	GENERAL INFORMATION	34
6.2.1	DEFINITION OF TERMS	34
6.2.2	ACRONYMS.....	38
6.2.3	UNITS OF MEASUREMENT.....	38
6.3	ATC DESIGN CRITERIA	39
6.3.1	ATC FUNCTIONAL GROUPS	39
6.3.2	POSITIVE TRAIN CONTROL (PTC).....	42
6.3.3	INTERFACE TO EVENT DETECTORS AND ATC SYSTEM RESPONSES.....	42
6.3.4	BROKEN RAIL DETECTION.....	43
6.3.5	ATC – MODES OF OPERATION.....	44
6.3.6	AUTOMATIC TRAIN OPERATION.....	47
6.3.7	BI-DIRECTIONAL SIGNALING	47
6.3.8	INTERLOCKINGS	47
6.3.9	TRACK CIRCUITS	48
6.3.10	WAYSIDE SIGNALS AND SUPPORT TO FALL BACK OPERATIONS.....	48
6.3.11	SWITCH MACHINES.....	48
6.3.12	IMPEDANCE BONDS.....	49
6.3.13	WAYSIDE ATC EQUIPMENT HOUSINGS.....	49
6.3.14	WAYSIDE ATC POWER SUPPLIES	49
6.3.15	REMOTE CONTROL AND SUPERVISION SYSTEM.....	49
6.3.16	YARD SIGNALING.....	50
6.3.17	RESPONSES TO DETECTION DEVICES	51
6.3.18	ATC INTEGRATION.....	51
6.3.19	DETERMINATION OF POSITION AND SPEED	52
6.3.20	HARDWARE REQUIREMENTS FOR VARIOUS SUBSYSTEMS	53

TABLE OF CONTENTS

ABSTRACT	1
1.0 INTRODUCTION	2
1.1 PURPOSE OF TECHNICAL MEMORANDUM	2
1.2 STATEMENT OF TECHNICAL ISSUE	2
1.2.1 ATC FUNCTIONS.....	2
1.2.2 TSIS AND ERTMS.....	3
1.2.3 OTHER CANDIDATE ATC SYSTEMS.....	3
1.2.4 ATC SPECIFICATION REQUIREMENTS	3
1.3 GENERAL INFORMATION	4
1.4 UNITS OF MEASUREMENT	4
2.0 DEFINITION OF TECHNICAL TOPIC.....	5
3.0 ASSESSMENT / ANALYSIS.....	7
3.1 GENERAL	7
3.1.1 ATP FUNCTIONS.....	7
3.1.2 ATS FUNCTIONS.....	8
3.1.3 ATC EQUIPMENT	8
3.2 ATC DEVELOPMENT WORK.....	11
3.2.1 ERTMS.....	11
3.3 ATC OPERATIONS – KEY CONSIDERATIONS	13
3.3.1 OPERATING MODES.....	13
3.3.2. AUTOMATIC TRAIN OPERATION MODE.....	16
3.3.2.1 Background.....	16
3.3.2.2 ATO Mode Benefits.....	16
3.3.2.3 CHSTP Application of ATO Mode	16
3.3.3 BI-DIRECTIONAL SIGNALING	17
3.3.4 INTERLOCKINGS	17
3.3.5 TRACK CIRCUITS	18
3.3.6 WAYSIDE SIGNALS AND SUPPORT TO FALLBACK OPERATIONS.....	18
3.3.7 SWITCH MACHINES.....	20
3.3.8 IMPEDANCE BONDS.....	20
3.3.9 WAYSIDE ATC EQUIPMENT HOUSINGS.....	20
3.3.10 WAYSIDE ATC POWER SUPPLIES	20
3.3.11 REMOTE CONTROL AND SUPERVISION.....	21
3.3.12 YARD SIGNALING.....	22
3.3.13 RESPONSES TO HAZARD DETECTION DEVICES.....	22
3.3.14 REGULATORY REQUIREMENTS.....	23
3.4 FURTHER ATC ISSUES TO ADDRESS	24
3.4.1 GENERAL	24
3.4.2 ATC INTEGRATION.....	24

6.3.21 TYPES OF DATA TRANSMISSION FROM TRANSPONDERS 53
6.3.22 LOCATION OF ON-BOARD ATC EQUIPMENT 54
6.3.23 ATC SAFETY REQUIREMENTS 54
6.3.24 RELIABILITY, AVAILABILITY, AND MAINTAINABILITY (RAM) OF THE ATC SYSTEM..... 55
6.3.25 DATA RADIO REQUIREMENTS 55
6.3.26 INTERFACES..... 55
 6.3.26.1 Rolling Stock..... 55
 6.3.26.2 Communications..... 55
 6.3.26.3 Traction Power..... 55
 6.3.26.4 OCS..... 56
 6.3.26.5 Track..... 56
 6.3.26.6 Infrastructure..... 56
 6.3.26.7 System Time..... 56

ABSTRACT

The California High Speed Train Project (CHSTP) requires the deployment of an Automatic Train Control (ATC) system that provides;

- Automatic Train Protection (ATP) functions of train detection, collision and overspeed prevention, broken rail detection, interlocking control, hazard detection, train separation, and work zone protection
- Automatic Train Operation (ATO) information and control functions
- Automatic Train Supervision (ATS) functions to provide central supervisors with status information and the ability to control train operations
- Positive Train Control (PTC) as mandated by the Rail Safety Improvement Act of 2008.

This Technical Memorandum describes the functions within each group and identifies how those functional groups will be met by the train control design, specification, and implementation phases.

The prime requirement for the CHSTP ATC system that has been identified in common with all systems is that the technology must already exist as part of an operating system with proven experience worldwide on at least one high speed passenger railway.

It is recognized that there are regulatory requirements from authorities such as the FRA, FCC, and CPUC which must be met and in meeting those requirements it might mandate changes to the proven system(s) in order to achieve certification from such regulatory bodies.

The purposes of this Technical Memorandum are to;

- Define the concept of the ATC system
- Describe the subsystems of the ATC system and the purpose of each.
- Identify the portions of the ATC system that will interface with and therefore impact the infrastructure, including the right of way, design.
- Identify the portions of the ATC system that will interface with and therefore impact the rolling stock design.
- Identify other portions of the ATC system that interface with and therefore impact the facilities and other subsystems of CHSTP.
- Identify the particular aspects of candidate ATC system that may be impacted by regulatory requirements from the FRA, FCC, CPUC, and other authorities and administrations.

1.0 INTRODUCTION

This technical memo addresses the concepts of the Automatic Train Control (ATC) system for the California High-Speed Train Project (CHSTP), describes the various subsystems, and addresses design considerations for the specification of the ATC and interfacing systems for procurement. CHSTP ATC will use existing, proven high-speed train control technology such as that used in Europe and Asia, or as adapted from proven U.S. ATC equipment, if practical. It is recognized that these proven high speed rail ATC systems do not meet all FRA regulations and that adaptation or equivalency must be demonstrated in order to achieve certification. The CHSTP will follow the Federal Railroad Administration's Rule of Particular Applicability process to achieve certification.

1.1 PURPOSE OF TECHNICAL MEMORANDUM

This Technical Memorandum serves several purposes;

- Defines the concept of the ATC system
- Describes the subsystems of the ATC system and the purpose of each.
- Identifies the portions of the ATC system that will interface with and therefore impacts the infrastructure (including the right of way) design.
- Identifies the portions of the ATC system that interfaces with and therefore impacts the rolling stock design
- Identifies other portions of the ATC system that interfaces with and therefore impacts the facilities and other subsystems of CHSTP.
- Identifies the particular aspects of candidate ATC system that may be impacted by regulatory requirements from the FRA, FCC, CPUC, and other authorities and administrations.

1.2 STATEMENT OF TECHNICAL ISSUE

1.2.1 ATC Functions

The CHSTP requires the deployment of an ATC system that supports the performance goals of the project including maximum speeds, trip times, and headway and that meets federally mandated practices and functions for a signaling system including Positive Train Control (PTC). The ATC system must ensure the following key safety functions; safe train separation, prevention of overspeed derailments, fail safe train detection, broken rail detection, interlocking rules enforcement, hazard response and work zone protection. The overall ATC system must incorporate the functions of Automatic Train Protection (ATP), Automatic Train Operation (ATO), and Automatic Train Supervision (ATS). These three functional areas of the ATC can be briefly described as;

- ATP – Automatic Train Protection – subsystem responsible for the safety-critical functions including PTC.
- ATO – Automatic Train Operation – subsystem responsible for the automatic operation of throttle and brake commands to move trains between stations and other stopping locations.
- ATS – Automatic Train Supervision – subsystem responsible for the centralized supervision and control of train movements including the back office server functions associated with PTC.

The functional sets are described in more detail in Section 2.

ATC consists of equipment and software onboard the train, along the track, in wayside equipment rooms, and in central and regional control facilities. In addition to the primary signaling related functions, ATC includes equipment such as snow melters and interfaces to other subsystems including hazard detectors and platform edge doors (if deployed on CHSTP).

1.2.2 TSIs and ERTMS

The CHSTP regulatory design approach is to model the requirements definition structure at the system level using the Technical Specifications for Interoperability (TSIs) as published by the Commission of the European Communities. The TSI governing signal requirements is Reference C(2006) 5211 for the command and control signaling subsystem. The TSI identifies a number of system requirements that are required to assure interoperability for trains from one European country to run on tracks in another. Following the TSI approach for CHSTP presents two significant constraints; one is that the requirements are specifically aimed at the European Rail Traffic Management System (ERTMS); the other is that they encompass system requirements for interoperability between the various member train control systems and are not comprehensive in describing the full set of requirements needed to specify an ATC system. ERTMS is composed of two Euro-standard subsystems; the European Train Control System (ETCS), and the European Integrated Radio Enhanced Network (EIRENE). ERTMS is specified in detailed documents produced by the UNISIG consortium; a group of international train control system suppliers. The ERTMS and EIRENE specifications together ensure that trains so equipped can operate safely and efficiently anywhere in ERTMS/EIRENE equipped territory.

ERTMS (and TSI) specifications do not specify the requirements of subsystems that are typically non-interface and legacy systems of the railroads from the EC member states. These subsystems include interlocking, train detection, and wayside equipment to support degraded mode operations in the event of a failure of a primary ATC subsystem.

1.2.3 Other Candidate ATC Systems

Other candidate ATC systems include;

- The TVM430 coded track circuit based system (originally developed by CSEE, now a division of Ansaldo) and related products that use coded track circuits
- Japanese coded track circuit technology deployed on the Shinkansen and Shinkansen derivative lines in Japan and other countries including Taiwan.

ERTMS and coded track circuit-based systems have significant differences; ERTMS detects train position using track circuits but conveys safety-critical information to trains in the form of movement authorities by means of a data radio network. Coded track circuit-based systems detect train position using track circuits but also send data to trains through the track circuit (running rails), similar to the way conventional cab speed signals systems work. Newer digital track circuits provide higher data rates than conventional cab signaling circuits, and can send messages to trains in real time that convey much more information than the traditional maximum speed limit.

1.2.4 ATC Specification Requirements

To enable qualified vendors of these proven ATC systems (coded track circuit and radio network based) to propose, this memorandum recommends that the ATC system specifications focus on ATC functionality and performance, and allows either coded track circuit or radio based systems.

As described above, the CHSTP is using TSIs to help define the project regulatory framework. For ATC, the TSIs do not specify the functional or performance requirements even at a system level. Therefore, this document defines ATC functional and performance requirements to the level needed to prepare bid specifications.

This Technical Memorandum describes the functions within the ATC and its ATP, ATO, and ATS functional sets, describes the locations where the equipment will be installed and the interfaces the equipment will have with other subsystems, and identifies how these functional subsystem requirements will be developed and met by the train control design, specification, and implementation phases.

The prime requirement for the CHSTP ATC system is that the technology must already exist as part of an operating system with proven experience worldwide on at least one high speed passenger railway.

Any candidate technology must also meet or be modified to meet the regulatory requirements from governing authorities including FRA, FCC, and CPUC.

1.3 GENERAL INFORMATION

Terms and Acronyms are contained in Section 6.

1.4 UNITS OF MEASUREMENT

The California High-Speed Train Project is based on U.S. Customary Units consistent with guidelines prepared by the California Department of Transportation and defined by the National Institute of Standards and Technology (NIST). U.S. Customary Units are officially used in the United States, and are also known in the U.S. as “English” or “Imperial” units. In order to avoid confusion, all formal references to units of measure should be made in terms of U.S. Customary Units.

2.0 DEFINITION OF TECHNICAL TOPIC

The technical topic of this memorandum is the provision of a high level description of the CHSTP Automatic Train Control system (ATC) requirements. These requirements include those identified in the relevant TSI for train control, and all others needed to define a fully functional ATC system for high speed passenger operation.

The term ATC refers to the train control system in main line and terminal territory yards. This memorandum also addresses the requirements for signaling trains in Yards. Yard signaling, although a signal system function and interfaced with the ATC system, is not normally considered to be part of an ATC system. ATC is divided into three functional sets;

- **Automatic Train Protection (ATP);**

The functional set responsible for the safety-critical functions including those of interlocking, train detection, signal aspects, broken rail detection, hazard detectors (if implemented as part of the ATC system), and movement authorities (including speed limit and cab signal commands if appropriate) that are sent to the train and acted upon by the on-board train control to enforce safe limits. The ATP functional set includes the enforcement of the safety-critical functions. PTC functions are part of ATP.

- **Automatic Train Operation (ATO);**

The functional set responsible for the automatic operation of throttle and brake commands to move trains between stations and other stopping locations (including those required due to the proximity of other trains and signal status) within the constraints imposed by the ATP functional set. Provides dwell timing at stations and the control or prompting of the opening and closing of train doors.

- **Automatic Train Supervision (ATS);**

The functional set within the automatic train control system that is responsible for the centralized supervision and control of train movements; the ATS monitors trains, adjusts the performance of individual trains to maintain schedules, and provides data to adjust service to minimize inconveniences otherwise caused by irregularities. ATS also provides automatic and manual route setting at interlockings and the identification and tracking of trains, the display of alarms and events, and logging and storage of event data.

These functional sets of requirements are analyzed in Section 3 of this Technical Memorandum. The ATC system consists of equipment and software onboard the train, along the track, in wayside equipment rooms, and in central and possibly regional control facilities. The subsystems consist of;

- **On-Board**

Equipment located on the passenger trainsets and maintenance vehicles including processors, firmware, software and electronics, operator displays, operator switches, data radios and antennas, transponder/balise antennas, code pick-up antennas, network components, GPS receiver and antennas, tachometers and other sensors, and all connections between train control elements and interfaces between train control and the train subsystems including propulsion and brakes.

- Wayside

Equipment located in housings along the right of way including station equipment rooms, train control equipment houses, and signal equipment cases and cabinets. Wayside equipment also includes the track circuits and associated hardware, switch machines, wayside signals, and transponders that are mounted on or about the track itself. The train control equipment located along the main line is part of the wayside equipment subsystem.

- Data Communications

The data communications network including dedicated network elements and components and data radio antennas and towers associated with the train control system. There is a portion of the data communications subsystem on-board the trains in the form of radios, antennas, and data networks. The on-board data communications equipment can also be considered as part of the on-board subsystem.

- Office

Equipment delivering ATS functions located in the Operations Control Center (OCC), at Regional Control Centers (RCC), and other designated facilities including station control rooms. Yard control towers will contain an office element for supervision and control of yard signal equipment but it is likely to be a separate set of equipment from the primary office subsystem (ATS) although it will be interfaced to that subsystem.

- Field Portable

Equipment for use by Employees in Charge (EIC) of maintenance and construction work in the field and used to manage track and other field systems access. It is used to communicate digitally and wirelessly with the office and on-board ATC subsystems to manage and control train movements through an active work zone.

- Yard

Equipment distributed throughout the yards and maintenance facilities for the operation of switches, signals, and enforcement devices to control train movements within Yard territory.

3.0 ASSESSMENT / ANALYSIS

3.1 GENERAL

The CHSTP is developing an ATC functional and performance procurement specification. If parts of the ATC system are procured in more than one contract, sufficient detail must be included to ensure that in addition to function and performance, the interfaces are adequately specified, the needs for maintenance and interchangeability are met, and the overall system meets its goals for safety, reliability, and availability. The CHSTP intends to minimize the number of suppliers of equipment of similar function in order to simplify maintenance and avoid carrying additional sets of spare parts.

This TM describes the required ATC system elements, why those elements are needed, and the engineering and operational issues that must be addressed in the ATC design and procurement.

The CHSTP ATC system must include the PTC functions that satisfy the Rail Safety Improvement Act (RSIA) of 2008 and the related regulation 49CFR236 Subpart I. For CHSTP, PTC will be an integrated set of functions within the ATC system where train collision and overspeed protection as well as the protection of roadway workers will be enforced. Although many PTC systems are being implemented as overlays on conventional wayside signal systems to meet the RSIA deadline of the end of 2015, CHSTP PTC will be an integral part of the ATC system.

For high speed operation, train safety must be assured by an automatic system that enforces speeds at all times, including the slowing of a train for an obstruction of the line ahead. Such obstructions can include a train ahead, a reduction in the civil speed limit (permanent or temporary), or an unset or unlocked switch in an interlocking ahead of the train.

3.1.1 ATP Functions

The basic safety-critical functions of the ATP functional set are;

- Enforce all speed limits on a train to prevent overspeeding through curves, switches, work zones, and other features that require speed supervision and enforcement to ensure safe operation.
- Ensure trains are separated to avoid rear end and side swipe collisions.
- Prevent derailments and collisions from movements through incorrectly set and/or unlocked switches and from conflicting train movements by setting and locking switched routes through an interlocking and only authorizing safe train movements through the interlocking

The train control system will also provide safe enforcement of other functions including ATC responses to hazard event detectors and sensors (provided by other subsystems) including;

- Earthquake
- Excess wind speed
- High water levels
- Excessive rainfall
- Underpass bridge strikes
- Landslide and rock falls
- Intrusion at trackside and in tunnels
- Intrusion from overhead bridges and at tunnel portals
- Intrusion at stations
- Dragging equipment
- Rail breaks

Although the majority of the listed hazard event sensors will be specified by other disciplines, many will be interfaced to at least one of the subsystems of the ATC, and the ATC will invoke the system response. In some cases, the ATS functional set will log the event and to display an event and/or an alarm to the operators for their further action; in other cases the ATP system will directly cause the train to enforce a braking activation and possibly stop trains in an emergency. Each sensor interface must be identified and the response of the ATC system to each interface agreed with Operations and other disciplines.

The ATC wayside equipment will include double-rail track circuits for train and broken rail detection. Track circuits are an approved means of detecting broken rails and this approach is acceptable to the FRA. A break in the rail must cause a false occupancy in a track circuit which in turn will result in a restrictive command being given to an approaching train. For track circuits to reliably detect broken rails and for the ATC system to protect trains, the ATC system must normally allow only one train in a track circuit at any one time.

3.1.2 ATS Functions

The ATS functional set will provide train management functions to assure the effective and efficient operation of a passenger train service. Such functions include automated routing and scheduling of trains and a means for dispatcher intervention to deal with incidents and emergencies.

3.1.3 ATC Equipment

The ATC system will consist of elements and subsystems that must be closely integrated to provide an overall solution for CHSTP operations. The ATC system must be closely integrated with other system elements, such as rolling stock, intrusion detectors, and hazard detectors, to ensure the necessary level of safe operation.

The ATC subsystems will consist of the following equipment;

- **On-board** – This subsystem consists of a combination of vital and non-vital equipment located on the passenger trainsets and maintenance vehicles. Vital equipment is used to fulfill the ATP functions, non vital equipment is used to fulfill all non ATP functions such as ATO and displays. The equipment includes processors, firmware, software and electronics, operator displays, operator switches, data radios and antennas, transponder/balise antennas, code pick-up antennas, network components, GPS receiver and antennas, tachometers and other sensors, and all connections between train control elements and interfaces between train control and the train subsystems including propulsion and brakes. Sensors and processors are used to determine position and speed, computer equipment, and operator controls and displays. Depending on the train control technology selected, the on-board equipment may also include data radios and antennas with which to communicate with the wayside and central control subsystems. The on-board subsystem may also include antennas and decoding equipment to detect digital signals transmitted to the train through the rails. The on-board package will receive data through the radio or the rails that define the movement authorities within which the train can safely operate. The actual speed of the train will be continuously compared to the authorized speed. If the train is to operate in ATO, the ATO functional set will handle any changes in speed called for. If the train approaches an overspeed condition the ATP functional set will generate a warning to the train operator. If appropriate action is not taken, the on-board system will intervene to ensure that the train movement stays within safe limits.

The on-board ATC will use sensors to determine the train's position to a high level of resolution both laterally (which track the train is on) and longitudinally, as well as

accurately measure speed. The enforcement of the Movement Authority limits enables the on-board system to provide the required PTC protections.

The onboard ATO functional set will regulate train performance when selected. Commands received from the ATS functional set may also provide for pacing trains at a lower speed than their maximum speed or increasing speeds from the pacing speed called for by the normal schedule. Under no circumstances can these ATO functions allow the train to operate faster or further than the safety-critical limits determined by the PTC functions of the ATP functional set.

The on-board ATC subsystem will interface with the rolling stock subsystems to support the ATP, ATO, and ATS functional sets.

In addition to interfaces required for the ATC system functions, additional train interfaces will provide remote monitoring capabilities of rolling stock subsystems. Remote monitoring allows for early diagnosis of trouble. Monitoring can be done using the office subsystem as part of the ATS functional set. Alarms and event indications can be displayed at the Operations Control center and the Regional Control Centers, or at ATS remote workstations at other locations.

On-board passenger information systems, including audible and visual announcements of real-time performance and other information to the passengers may be provided from the Office subsystem through the ATC data communications subsystem or by an independent data communications subsystem.

The on-board ATP functional set equipment will interface to wireless or above-rail inductive antennas that receive Movement Authority commands from wayside ATP functional set equipment. A data radio subsystem will provide data transmission between the train and wayside.

- **Wayside** – consists of mainly vital equipment located in housings along the right of way including station equipment rooms, train control equipment houses, and signal equipment cases and cabinets. The equipment includes track circuits, switch machines, wayside signals, interlocking equipment, and transponders (or balises), much of which is considered to be conventional signal system equipment. This equipment includes ATP electronics that is either integral to or interfaces with the track circuit and interlocking equipment and to other sensors including intrusion, seismic, and other detectors that will allow the train control system to react to an event and bring the train to a safe speed if necessary. The ATP processors obtain track circuit occupancy status, interlocking route status, and sensor device status in order to output messages to the trains that define the safe limits (including distance to go and target speeds) for train movement. Equipment will be housed in a distributed fashion along the rail line to provide continuous coverage including along aerial structures, through tunnels, in yards, and in stations.

Interlocking functions including route setting, route locking, approach locking, and sectional release will be performed by wayside microprocessor interlocking equipment.

The wayside subsystem will be linked by the data communication subsystem to allow supervision and remote control from the Operations Control Center (OCC) and the Regional Control centers (RCCs).

Site requirements for ATC equipment at the wayside are described in Technical Memorandum TM 3.3.2; Automatic Train Control (ATC) Site Requirements.
- **Data Communications Subsystem (DCS)** – Communicates data, commands, indications and alarms between ATC subsystems and locations. This consists of connected networks of wireless, fiber optic, and hardwired equipment.

The DCS will carry both vital (ATP) and non-vital (ATO, ATS and management) information. The DCS itself does not have to be a vital subsystem. Coding and other techniques in the other ATC subsystems ensure that the data received is of sufficient integrity and currency that it can be treated as accurate for vital applications. ATP equipment will reject any data for a vital function that cannot be validated.

Many DCS elements, including electronics, fiber cables, radio equipment, and antennas will be on CHSTP property. However, the diversity that may be needed to deliver the specified communication link availability may require the use of leased communications lines provided by a third party as backup to the primary links. Some radio antennas may also be located off CHSTP property where propagation considerations indicate a benefit.

The candidate ATC system ERTMS uses 900 MHz GSM-R radio to communicate movement authorities and safety-critical data between train and wayside. These specific bands are not available within the U.S. It is essential to identify one or more suitable bands with sufficient bandwidth and reserve them through licensing and/or other means for exclusive CHSTP use to ensure reliable system operation.

- **Office** –The ATC Office subsystem supports the majority of the ATS functional sets. It consists of a centralized or a distributed computer control system with dispatcher workstations that provides the overall CHSTP train operation management functions including remote routing and supervision functions. It includes announcements of events including critical alarms and a logging capacity for all events. It generates many system performance reports. Many ATS functions supported by the Office subsystem are automated, including setting of routes at interlockings, regulation of train movements in accordance with the schedule, movement planning, and the recovery of the service from minor interruptions and failures.

At any time, dispatchers can take manual control of route setting and schedule regulation functions from their ATS workstations in accordance with the rail management plans and procedures. Recovery from major interruptions and failures will likely require manual intervention of the dispatchers. The general arrangement of control positions by function and responsibility, including responses during failures and incidents, will be described in the Concept of Operations document.

The Office subsystem architecture can be centralized or distributed to provide reliable computing power and the required workstations that allow supervisors to dispatch the services, monitor subsystem performances, and intervene to manually supersede automated processes in the event of incident and emergency. The territory controlled by each workstation can be adjusted by an appropriate official such as the Chief Dispatcher to adjust to workload demands as they fluctuate. As workstations can be in centralized or distributed facilities, or at remote locations, the ATC system can support a flexible approach to the overall supervision of the CHSTP rail operations.

The Office subsystem communicates with wayside locations, remote workstations, trains, other ATC elements, and sensors including intrusion, through the data communications subsystem.

The Office subsystem will provide workstations primarily within the Operations Control Center (OCC) and the Regional Control Centers (RCCs).

- **Field Portable** – Equipment for use by Employees in Charge (EIC) of wayside work; it will be used to manage track and other wayside systems access. EIC portables will communicate digitally and wirelessly with the ATS and with on-board ATC subsystems to control train movements through a work zone. Trains may only operate through established work zones with the agreement of the EIC who can use the field portable equipment to enforce reduced speeds and track blocks. Although generally maintenance work on the tracks will be done outside of revenue hours, EIC portables will protect all

worksites and zones on or about the track, from movements of ATC-equipped maintenance vehicles and passenger trains.

- **Yard** – Equipment distributed throughout the yards and maintenance facilities for the operation of switches, and to provide wayside illuminated signals, and enforcement devices to control trains movements within Yard territory. Red signal aspects will be enforced such that trains cannot pass a signal displaying a stop indication and cannot enter an unlocked switch or stop foul of a train movement authorized on another track.

Control of the Yard signaling systems will be from a panel or workstation located in a control room (or tower) within the yard facility.

Train movements between yards and the main line will be routed through transition tracks where trains will transition between ATC and Yard signal system modes of operation.

3.2 ATC DEVELOPMENT WORK

Work during the CHSTP design development phase is identifying candidate ATC technologies, developing system requirements, and defining interfaces between ATC and other CHSTP systems. These will enable procurement of an ATC system with the needed functions, safety, reliability and availability for CHSTP operation.

Using ATC technology developed under a foreign regulatory framework requires extensive analysis of the FRA CFR requirements for signaling systems, including the new PTC regulations issued as 49CFR Part 236 Subpart I.

The adopted regulatory basis for the CHSTP system design includes applicable portions of the European Commission Technical Specifications (TSI). Although the TSI for Command and Control is slanted towards the European Rail Traffic Management System (ERTMS, the CHSTP has not selected ERTMS for CHSTP ATC.

The CHSTP design criteria will include requirements that address any gaps between the TSI-based System Requirements and the FRA regulations.

3.2.1 ERTMS

The European Rail Traffic Management System is a candidate technology for the CHSTP ATC system. It is specified to three levels of functionality;

- Level 1 is a simple fill-in where signal aspects are conveyed to trains by intermittent loops
- Level 2 uses radio to continuously convey track circuit occupancy and other data to trains. Levels 1 and 2 use track circuits for train detection.
- Level 3 is the most technologically sophisticated system. It does not require track circuits; it primarily uses on-board vital equipment to determine train position.

Level 3 does not use track circuits; instead the on-board ATC equipment will determine train position with much higher resolution than can be provided by track circuits. A Level 3 ERTMS system will approach moving block capability. The term moving block describes a system in which following trains are separated by the braking distance of the following train plus a safety buffer distance. This separation is typically much closer than that supported by a track circuit (or fixed block) signaling system.

To date several ERTMS Levels 1 and 2 systems have been implemented and have actual revenue experience. This is true for both conventional speed railroads and for high speed lines approaching 200 MPH. ERTMS systems are also being developed and employed outside the EC. In December 2009, the Chinese high speed line (Wuhan to Guangzhou High Speed Railway) opened, with a top speed of 245 mph. It is equipped with a Chinese Train Control

System (CTCS) Level 3 train control system. However, the CTCS Level 3 ATC is similar to the ETCS Level 2 system, using track circuits and radio; it is not similar to the ERTMS Level 3 system.

No ERTMS Level 3 systems have been deployed yet, and the ERTMS Level 3 equipment is not yet commercially available and viable. Even if and when ERTMS Level 3 is proven in service, for CHSTP, a significant ERTM Level 3 technical and regulatory issue concerns the use of track circuits to detect broken rails. Currently all high speed rail operations globally use track circuits both for basic train detection and for broken rail detection. Since ERTMS Level 3 does not include track circuits, it cannot fulfill the CHSTP broken rail detection requirement without some added provision.

Because 49CFR236 requires a proven means of detecting possible broken rails, CHSTP will specify track circuits. This makes ERTMS Level 2 a contender for CHSTP ATC for the following reasons;

- ERTMS Level 2 uses track circuits as a primary train location subsystem
- It has been widely deployed on high speed rail routes in Europe and other countries and is therefore a proven system
- It has been deployed on systems with similar maximum speeds and headways as CHST design goals
- There are multiple suppliers of hardware and software; these suppliers have subsidiaries in the United States

ERTMS includes both the train control data radio and operations voice radio between the wayside and trains. The EIRENE (radio) component of ERTMS operates in the GSM band that has been dedicated throughout Europe for railway operations (GSM-R (Railways)); it carries both voice and train control data circuits. There is no GSM-R band dedicated to railroad operation in the United States. If ERTMS is to be deployed on CHSTP and appropriate radio frequency channels cannot be secured from the FCC, ERTMS will require adaptation with respect to data and voice radio communications.

3.3 ATC OPERATIONS – KEY CONSIDERATIONS

The following table addresses key operational issues with respect to the ATC system definition.

3.3.1 Operating Modes

The following table operating modes and sub-modes are planned for operation of CHSTP trains on main line and in yards and depots;

MODE OF OPERATION	ATO OR MANUAL OPERATION	MAX TRAIN SPEED	ENFORCED BY	NOTES
ATC	ATO	Line Speed or as defined by Limit of Movement Authority	ATP	<p>This is the normal operating mode on the main line which includes automatic operation of Rolling Stock propulsion and brakes by the ATO subsystem within ATC.</p> <p>Requires an action by the Train Operator to select ATO mode. ATP system must determine that other factors are correctly set before train can move in ATO mode (Movement Authority is being received by on-board ATP subsystem, doors are closed and locked, etc.)</p> <p>Rolling Stock subsystem requirement must include the incorporation of the vigilance/alerter device to ensure The Train Operator is in the cab and alert. Rolling stock vigilance/alerter device is required in all modes of operation including ATC, RM, Bypass Yard, etc.</p>
ATC	Manual	Line Speed or as defined by Limit of Movement Authority	ATC	<p>This is the operating mode on the main line where movements and speeds are fully supervised and enforced by the ATC system but the propulsion and brakes are commanded by the Train Operator</p> <p>Vigilance/alerter function to be provided by Rolling Stock; see note above.</p> <p>CHSTP ATC may include a Call-On mode to allow the train to pass a red signal under certain controlled conditions. If so, this will be a sub-mode of ATC/Manual. To enter it, the ATC system will send the train a Call-On command. ATP will enforce a speed limit of 20 MPH.</p>

MODE OF OPERATION	ATO OR MANUAL OPERATION	MAX TRAIN SPEED	ENFORCED BY	NOTES
<p>Restricted Manual (RM)</p>	<p>Manual</p>	<p>FRA requirement of Restricted Speed. Restricted is 20 MPH or lower, as required to stop within half of range of vision.</p>	<p>ATC on-board subsystem</p>	<p>A degraded Mode. In this mode the On-board ATP subsystem will limit train speed to 20 MPH maximum. Train Operator will work in accordance with procedure and observe the wayside signals for authority to move. Movement authorities, including speed commands are not received in this mode. In the event of receipt of a speed command or Movement Authority from the wayside while in RM mode, the on-board ATC will automatically switch to ATC Manual mode. RM mode addresses short term ATC failures such as movement through a failed switch (under procedure) or through a failed track circuit (which can include a broken rail) outside an interlocking. Movement through an interlocking with a failed track circuit can be done under Call-On mode (see above).</p>
<p>Yard or Depot</p>	<p>N/A</p>	<p>Yard speed limit</p>	<p>ATC ATC will enforce yard maximum speed limit not exceeding 20 mph per 49CFR236 Subpart I.</p>	<p>The Train Operator will select the transition from ATC Manual mode to yard and vice versa when a train is stationary on a transition track when entering or departing a Yard. Yard signal enforcement is required however the safety criteria used in the design will not be as restrictive as for the main line ATC system. Trains approaching a shop track from the Yard will require a Train Operator acknowledgement before being allowed to enter a shop track. Yard mode can treat a shop entrance as an end of track and further movement forward can be in RM mode. This will be considered as part of an Operations Hazard and Risk analysis. If a wayside ATC failure affects Yard mode, RM mode is the most appropriate mode for further train movement, protected by procedure. If the on-board ATC fails, then the Train Operator must select ATC Bypass for further train movement, protected by procedure.</p>

MODE OF OPERATION	ATO OR MANUAL OPERATION	MAX TRAIN SPEED	ENFORCED BY	NOTES
<p>Bypass</p>	<p>N/A</p>	<p>FRA limited speed is 59 MPH per 49CFR236 subpart I.</p>	<p>Rolling Stock propulsion and possibly braking subsystems.</p> <p>This is a mode NOT enforced by ATC. In this mode, ATC is in Bypass mode and is not connected to the rolling stock equipment.</p> <p>Safe operation of trains is maintained by home signal indications, by rules and procedures, by regular training and refresh.</p> <p>The maximum speed limit of 59 MPH will be enforced by the rolling stock propulsion subsystem.</p>	<p>A degraded mode.</p> <p>This mode is used if the on-board ATC fails.</p> <p>Will require a separate Bypass switch that will be sealed normally in the ATC (not Bypassed) position.</p> <p>No secondary enforcement system is required other than a maximum speed supervised by the Rolling Stock propulsion subsystem.</p>

3.3.2. Automatic Train Operation Mode

3.3.2.1 Background

In ATO mode, an on-board ATO subsystem that controls the operation of rolling stock propulsion and brakes, to start a train at a station, accelerate it, regulate its speed to below the speed limit, move the train between scheduled station stops, and brake the train to a precision stop at the next station, all subject to Movement Authority limits set by the ATP subsystem. ATO mode is extensively used in transit systems worldwide, but has had limited use on main line and high speed lines. ATO is now starting to be deployed on passenger main line tracks including high speed operations outside the U.S.

The Taiwan High Speed Train (HST) system uses an ATO mode called Programmed Station Stop Control (PSSC). PSSC slows and accurately stops trains at stations; it does not start trains from stations or provide speed maintaining between stations. The Train Operator controls the train acceleration and speed for those phases of a trip. When the Train Operator activates PSSC on the approach to a station, the on-board ATO subsystem takes control of the train propulsion and brakes, and using track transponders to determine distance to go, automatically slows and stops the train in accordance with a programmed speed/distance profile.

3.3.2.2 ATO Mode Benefits

Operation of trains in ATO mode has several benefits;

- Allows consistent optimized operation up to the maximum safe speed, resulting in closest headways and minimum trip times.
- Facilitates accurate and timely station stopping with no running time loss due to cautious operators and with minimum risk of over- and undershooting station platforms. ATO mode provides benefits at all speeds and will provide even greater benefit for station stopping in the higher speed sectors where judgment of distance is more difficult.
- Supports a positive “berthing” function whereby train doors are interlocked by the on-board ATC system and only release on the correct side and when the train is stopped properly within the platform limits. This function together with accurate stopping capability supports the potential implementation of platform edge doors at stations.
- When used with schedule regulation functions integrated with an intelligent ATS subsystem, it supports on-time performance, improves recovery from service delays, and improves efficiency of merges at rail junctions.
- In conjunction with ATS, ATO supports energy management speed control strategies which reduce energy usage by considering track grades and planned arrival times in setting a target speed below the ATP speed limit.
- Provides consistent operation of trainsets resulting in lower wear and tear on rolling stock

ATO station stopping, already in service on the Taiwan HST, overcomes a major difficulty with operating high speed trains - the inconsistent ability of Train Operators to judge stopping distances. For a station stop from high speed, braking must start well before the station is in sight; wayside markers (which might otherwise be used) have little or no value when approached and passed at high speed.

3.3.2.3 CHSTP Application of ATO Mode

ATO mode operation will be incorporated into the ATC system design for all phases of station-to-station running on the main lines and for exit and entry to yards including;

- Acceleration from station stops
- Cruising at safe speeds determined automatically by the schedule regulation function of the ATS subsystem, or manually set by console dispatchers through the ATS workstations, or as determined by an Energy Management function.

- Stopping and restarting for ATC enforced stops defined by movement authorities
- Exit from yard transition tracks within yards to the main line
- Entry to yard transition tracks from the main line
- Station stopping
- Energy management

ATO mode requirements will be incorporated in the interfaces with rolling stock and other impacted subsystems.

Further consideration must be given during the design phase to the following;

- An important human factors issue is to keep the Train Operator engaged during extended runs in ATO mode. Considerations include the Train Operator's interactions with a vigilance device, the train and the on-board ATC system; and procedures that require manual driving at intervals to make sure the Train Operator can correctly operate the train when needed. This is a special concern to the FRA, as noted in the preamble to 49CFR236 Subpart I.
- Are sub-modes required such as full ATO mode and Programmed Station Stop Only mode?
- Prerequisites to enter ATO mode and start the train, including door interlocks and Train Operator cab console controls that interface to the on-board ATC equipment. Can ATO mode be entered or canceled on the fly?
- What are ATO mode requirements for safe and reliable operations during reduced adhesion conditions because of autumn leaves on the line and light or heavy rain?
- Is ATO required only on the main lines or is it a low speed ATO mode required in the yards and/or the train wash tracks?
- Operational restrictions and procedures may govern ATO mode use; for example;
 - When maintenance personnel are working on or about the track during traffic
 - If there are special restrictions on the Peninsula Corridor.

Detailed procedures will be written during the construction and test period. The decision to apply ATO and its sub-modes is subject to further discussion and will be a decision for the Operator.

3.3.3 Bi-Directional Signaling

Planned CHSTP passenger train operations will use one track exclusively in a single direction. Nonetheless, the ATC design will provide bidirectional running capability. With microprocessor interlocking and signal equipment, the cost of bidirectional signaling is marginal, resulting only from possible additional wayside signals and marker boards (see later section on wayside signals). With bi-directional signaling, if a wayside failure blocks a section of track, trains from the failed track will be safely and automatically routed onto the opposing track to bypass the failed track section. Traffic locking will allow safe following moves and prevent routes being cleared into tracks in opposing directions until the section between interlockings is clear. Trains operating in both directions on a mainline track equipped for bidirectional operations will operate with all ATC modes and functions available, including PTC and possibly including ATO for station stopping.

3.3.4 Interlockings

Interlocking functions are part of the ATP functional set. Interlocking functions will be provided by microprocessor interlocking equipment. Use of conventional signal relays will be minimized. Interlocking requirements will include route clearing, approach locking, detector locking, route locking, traffic locking, indication locking, time release, sectional release, and other functions.

Approach locking will be provided as the intermediate interlockings between stations will normally be fletted. Interlocking equipment will be interfaced with other ATP equipment to send movement authorities to trains that will ensure safe movement through interlockings.

Wayside signals will only be located at interlockings. The wayside signals will only indicate the status of routes at their entrances. These wayside signals will not be the primary indication of route status; the primary indication will be the Train Operator's display in the cab.

3.3.5 Track Circuits

CHSTP will use a track circuit based ATP subsystem.

In all HST operations now in service, the ATC systems use track circuits for primary train location detection.

Japanese Shinkansen and European TVM 430 ATC systems use track circuits for primary train location detection and also for the transmission of movement authorities to trains; the ERTMS ATC systems uses radio for movement authorities).

Track circuits fulfill the FRA requirements for detection of broken rails. In the event of a broken rail, the ATP subsystem will assume a train is present and prevent a following train from entering the apparently occupied block. Further movement will be under procedure, allowing the Train Operator to observe the track ahead to determine if a broken rail does exist.

The ERTMS Level 3 specification allows for a system that does not use track circuits; however, there is no ERTMS Level 3 system currently in service or construction. As noted above, ERTMS Level 3 uses the on-board derived location information and transmits this to the wayside ATP equipment for use by other trains to determine movement authorities (in addition to other factors) based on the reported position of trains. Train integrity is also required with Level 3 to assure that no portion of the train is left behind when the front of the train advances.

ERTMS Level 3 development has stalled due to the complexity of the safety case combined with industry support of Level 2 deployments. Even in Level 3 ERTMS systems, some track circuits may be needed for interlocking functions, particularly in the event of ATC failures.

3.3.6 Wayside Signals and Support to Fallback Operations

ATC system failures can be divided essentially into two key event impacts;

- A single train can be affected for a significant distance and time by the failure of the on-board ATC equipment
- Several trains can be affected over a limited distance and time by a failure of wayside ATC equipment.

A failure with similar impact on train operations is a broken rail, which will be detected by a track circuit. Track circuit failures will be treated by the ATC system as a broken rail event until proven otherwise.

Normal ATC operation will not depend on use of wayside signals. The ATP subsystem design will provide some visual signals and signs at the wayside for fallback operations. Such signals are not of practical use when operating at high speeds (e.g., greater than 150 MPH). However, they will be usable in degraded operating modes when the on-board ATC system that generates cab displays of movement authorities is not available.

The CHSTP ATC design presently plans wayside signals at the following locations;

- At the entrance to interlocking routes (home signals)
- In Yards

The prime use for mainline signals is to support safe train operation when the primary on-board or wayside ATC subsystems is not available and when movement authorities cannot be received and enforced by the on-board ATC subsystem.

Home signals will be provided on main lines only at the entrance to interlocking routes. Intermediate signals will not be provided. At high speeds, signals will not be visible in a useful way to the Train Operator, so the Train Operator must follow the cab signal indications or operate the train in ATO mode. During failures of the primary on-board or wayside ATC system, the maximum train speed will be limited to 59 mph, the limit in 49236CFR subpart I, maximum speed when operating with failed PTC system. In addition, under present rules a train with an ATC failure that occurs while the train is between interlockings must be operated at Restricted Speed until it passes a wayside signal that indicates that there is no broken rail in the signal block ahead.

As noted above, ATP subsystem design criteria will require main line home signals at the entrance to interlockings and signals to control mainline access from refuge tracks. A headway requirement to be supported by wayside signals will not be specified.

The ATP subsystem design criteria will specify the type of signal and supporting structure. Dwarf signals minimize installation cost and reduce life cycle maintenance cost due to easier access for inspection and repair. The final decision on signal type will depend upon the agreed maximum speed when operating in degraded mode. 49CFR23 Subpart I specifies a speed of 59 mph or less for passenger trains operating in degraded mode without PTC functions, although the CHSTP may petition for a higher speed under the Rule of Particular Applicability that will be required from the FRA to begin revenue service.

A risk analysis will evaluate factors related to train movement in the event of relevant ATC system failures. The analysis will consider maximum speeds allowable, signal sighting distances and the need to enforce the signals or not. If wayside signals will not be enforced, the sighting distance for each signal will be critical. In that case, high signals may be required, especially on grades and curves. Approach signals to interlockings may also be required.

Extensive backup signal systems are undesirable in a number of ways;

- With high availability of the prime ATC, the backup system will get only occasional use; Operations personnel will need refresher training to stay current. This will impact their availability for normal operations.
- Added maintenance and regular test will be required for backup wayside and on-board (if provided) equipment.
- Added cost and technical complexity of the overall ATC system; benefits are yet to be fully evaluated but current assumptions are that they will be very limited.
- Backup signaling must be tied into the prime ATC system; failures of the backup can impact normal ATC availability and reliability. In any event, more equipment means lower overall reliability and an increased level of maintenance activity.

The present design is that speed enforcement in degraded mode will be provided by a speed governor function in the propulsion subsystem. This governor will be activated by the ATC cutout switch in the operating cab. If the train speed exceeds the defined maximum (e.g., 59 MPH) then the propulsion subsystem will cut power to the motors and an audible and visual alarm will sound in the cab.

The ATC system procurement specification will specify high availability normal operating modes so that CHSTP can provide dependable, on-time service. Considering the excellent availability, of HST service worldwide, CHSTP should rarely experience degraded mode operations. Information from Shinkansen systems experience is that the fallback systems are used sparingly and operating staff have little experience of their use.

If the fallback system is complex and equipment-intensive, this will reduce overall reliability due to the increase in hardware. This could also reduce availability as fallback system equipment failures can impact the availability of the prime ATC system under certain circumstances.

3.3.7 Switch Machines

Powered switch machines will be provided on all switches, and on moveable point frogs on the Main Line and in yards (see later in this section). The design team will determine the number of switch machines for each type of switch (which can be up to 8 machines per switch end for the highest speed turnouts) for the purposes of preliminary engineering and cost estimating. The actual number of machines needed to meet the functionality and RAMS performance requirements for the project will be detailed, to ensure consistency between line segments and to ensure a uniform maintenance approach on all parts of the CHSTP system.

Yard switch machines will be of a different type from mainline; see the section on Yard Signaling later in this document.

Some but not all switches will require heating devices (snow melters) that will keep switches operating during periods of snow and/or ice. These will be required for the interlockings at higher elevations where snow and ice can occur. Power for these devices will be taken from the OCS with a transformer and control equipment mounted on the OCS poles and in wayside equipment cases.

3.3.8 Impedance Bonds

Impedance bonds will be required at traction power facilities; at track circuit boundaries and possibly other locations including insulated joint locations at interlockings and at intermediate locations where ground connections must be made to the Overhead Contact System (OCS) static wire. Grounding may also be required at impedance bonds at track circuit boundaries. Engineering must be done to determine where these ground connections can be made to ensure correct track circuit operation under normal conditions; to ensure that touch potential criteria are met; and to ensure that the track circuits will correctly detect a broken rail. The Final Designer will coordinate with the traction power engineers in developing the track circuit and impedance bond locations.

3.3.9 Wayside ATC Equipment Housings

ATC equipment will require wayside housings whose size and type will depend on the location. The larger "house" enclosures (that maintainers can enter) are needed at interlockings; smaller wayside cases (where maintainers can access the equipment inside but cannot enter the case) will be adequate near track circuit boundaries. Other locations which may also require wayside housings including interface locations with event sensors including roadway underpass impact sensors, seismic detectors, wind speed measurement equipment, etc.

ATC housings must accommodate ATC communications equipment. Such equipment includes fiber drop and network equipment as well as data radios.

Site requirements for ATC elements are covered in Technical Memorandum 3.3.2; Train Control Site Requirements.

3.3.10 Wayside ATC Power Supplies

Alternating current power supply for ATC wayside equipment will be straightforward at stations and interlockings, where utility feeds are probably available. However, track circuit equipment at approximately one mile intervals requires ac power, and in remote, desert, and mountainous regions, a utility supply line could be difficult or expensive.

Alternatives to utility feeds are being considered, including dedicated signal power feeds from adjacent ATC sites that have utility power feeds, drops from the OCS, solar panels, and wind turbines. In each case, the sources will be supplemented with local batteries.

Power supplies for wayside ATC equipment is addressed in Technical Memorandum 3.3.3; Train Control Wayside Location Power Supply Options.

3.3.11 Remote Control and Supervision

The CHSTP remote control and supervision strategy will impact the ATS functional set and Office subsystem specification. The present design includes ATS functions, performance requirements, and hardware as part of the ATC system.

Many ATS functions, including automatic dispatching of trains and routing through interlockings and terminals, will be accomplished automatically with manual intervention only required in the event of system failure or unplanned occurrences.

The Office subsystem design assumes;

- The ATS prime location will be in the main Operations Control Center (OCC)
- Remote workstations will be located in at least two other locations (Regional Center(s)) that will allow dispatching in certain regions, including the common and shared corridors to be done relatively locally.
- The Regional Control Centers (RCCs) will be capable of taking over dispatching of any and all of the CHSTP system in the event of major incidents and failures.

Availability considerations may require that Office subsystem core equipment including communications and database servers be located in the OCC, Regional Centers, and possibly other sites; with options for cold, warm, and hot standby of the backup systems. The purpose is to ensure that even if a major incident that knocks out the OCC (earthquake, sabotage/terrorist action, major fire, etc.), centralized Supervision and Dispatching can continue with little or no interruption to train operations.

Current planning has identified that dispatching of the peninsula corridor will require a regional center to handle CHSTP and Caltrain services between San Jose and San Francisco. This Regional center would be staffed 24/7 and could be considered a location that could assume supervision and control of the full CHSTP network during a major incident.

In emergencies, the control of interlockings can be taken from a Regional Center or a station control room.

A further level of degraded operation of an interlocking can use the local control panel connected to the nearby ATC house, in the station control room or the adjacent station. Although ATC local control facilities will be specified in the stations, the reliability/availability of the communications subsystem makes the loss of control from the ATS highly unlikely.

Consideration will also be given to a form of field-fallback mode for the remote interlockings in which they will revert to normal routes being called and fleeted in the event of a loss of communications with the ATS. This fleeted fallback mode can be overridden from a local control panel if it is necessary to operate the intermediate interlocking with ATS communications down. The local control panel in the interlocking control house will allow local control in emergencies and for maintenance testing needs.

For control of Yard movements, each yard will have a local tower with local control panels or workstations where a Yard Dispatcher can route trains within the Yard and shops. Electronic handover of trains between the main lines and the Yard tracks will be accomplished via an interface between the mainline ATS system and the Yard ATS workstations. See the next section on Yard signaling.

3.3.12 Yard Signaling

The Yards will require a signal system to operate switches and control movements of trains in the yard itself and for transitions between the Yard and the mainline.

The present design assumes there will be powered switch machines and low level signals at the Yard wayside. Switch machines will be of a common yard type and not main line machines. Yard machines are cheaper and can provide a trailable feature which lowers the risk of damage to equipment and of derailment if a train should trail a switch set in the wrong position for the move.

Enforcement of signals and protection of trains and workers in the Yards will be provided by a subsystem yet to be determined. There may be some use of power-operated derails for this function. There will need to be functional interlocking between signals, derails, and switches, although the level of safety in a Yard system is typically less than specified for the mainline. Trains will operate in some form of Yard mode (see the Operating Modes table above).

Control of Yard signals, derails, and switches in Yards will be from local Yard towers and not from the Central or Regional Control Centers. The operation of the control panels or workstations in the Yard towers will be undertaken by a depot Controller or yardmaster.

Maximum speed enforcement in the Yards will be by the on-board subsystem. In order to be exempt from installing PTC in the Yards, the speed limit within the Yard cannot exceed 20 mph per 49CFR236.1019(b)(1).

Access and exit from shop tracks into the Yard proper will also be protected by means of power-operated derails.

Train movements between Yard and mainline will use bi-directional transition tracks. On-board ATC equipment will transition from Yard mode to ATC mode of operation and vice versa automatically. Trains departing the Yard to the mainline must pass an automatic on-board ATC subsystem check before the wayside ATC equipment will route the train or send it a Movement Authority or valid speed and destination code. The transition tracks must be treated by Operations and Maintenance personnel as mainline track, since trains will operate in ATC modes, including ATO mode. ATO mode will be possible leaving the transition track for the mainline and when entering the transition track from the mainline. ATO mode will not be available for movements between the transition track and the Yard in either direction.

3.3.13 Responses to Hazard Detection Devices

CHSTP will use an array of hazard detectors. The hazard detector types may include;

- Earthquake
- Excessive wind speed
- High water levels
- Excessive rainfall
- Road and rail underpass bridge strike
- Landslide and rock fall
- Intrusion at trackside and in tunnels
- Intrusion from overhead bridges and at tunnel portals
- Intrusion at stations

Each hazard detection type will be evaluated for the level of risk each hazard can pose to CHSTP operation; the interface to the ATC system; and the required ATC system response. ATC system responses can include;

- Automatically change from ATO mode to Manual-ATP mode. (Note that if the ATO function uses a “hands off” approach, this will apply the service brakes until the Engineer takes the controller).
- Stop the train immediately with a service brake
- Stop the train immediately with an emergency brake
- Block an affected section of track. The on-board ATC equipment for each nearby train determines the level of brake needed to avoid entering the blocked track or to stop the train if it is already entering or in the affected track section.

For track intrusions at stations, the choice is between automatic sensors of intruding passengers vs. customer/staff operated alarms.

If a hazard detector is connected directly to the ATC system and a train response is forced, the hazard detector comes under FRA regulation. If the detector is interfaced to the ATS to generate and alarm at OCC, it is not.

Consideration needs to be given to the response types required for different levels of intrusion.

The EMT will further consider a need for Dragging Equipment Detectors (DED). If not necessary on the CHSTP tracks themselves, certain DEDs may be required on approach tracks used by freight or other passenger trains (e.g. Caltrain, Amtrak, and Metrolink) which may occasionally run on CHSTP tracks. The reason to place DEDs at approaches is to protect the CHSTP tracks and any track mounted equipment from damage by occasional users. High load detectors to protect the overhead contact system from freight trains may also be needed.

Where there are physical track connections to other railroad operator’s tracks, the ATC system will require a function that prevents unauthorized trains, including freight, from being routed onto CHSTP tracks even on shared corridors.

3.3.14 Regulatory Requirements

To receive the FRA Rule of Particular Applicability permitting CHSTP operation, the CHSTP must demonstrate that the ATC system satisfies the respective CFR signaling requirements, including design, testing, and on-going maintenance.

49CFR236 Subpart I, published in January 2010, defines the requirements of PTC and the processes by which FRA certification of the PTC elements of the ATC system can be achieved. For existing railroads, the regulations impose a deadline of April 16, 2010 for submittal of the PTC Implementation Plan and either a PTC Development Plan or a Notice of Product Intent. A non-operational railroad that is yet to be designed and built, such as CHSTP, must be certified before beginning revenue service. To be certified, CHSTP must submit and receive FRA approval for a PTC Development Plan, a PTC Implementation Plan, and a PTC Safety Plan. The CHSTP System Requirements which the CHSTP is now submitting to the FRA for comment will clearly show that the requirements of PTC and the processes laid down by 49 CFR236 Subpart I will be met by the CHSTP ATC system. Nonetheless, the rule-mandated documents must be submitted and approved before the start of revenue service.

The CHSTP will establish a schedule of 49CFR236 Subpart I submittals with the FRA that will provide adequate time for reviews of all plans (including implementation, development, safety, test, and training), test results, operating and maintenance rules and procedures, and final application for certification, such that testing, trial running, and in-service dates can be met.

The CHSTP will also address and comply with relevant CPUC requirements.

The CHSTP will also address and comply with Federal Communications Commission (FCC) licensing requirements for transmitters that include voice and data radios and transponder antennas, including registration of antenna towers where necessary with the Federal Aviation Administration (FAA) where CHSTP runs close to airports.

3.4 FURTHER ATC ISSUES TO ADDRESS

The matrix on the following pages describes the key issues to be addressed in the development of the ATC system design criteria and specifications. The documents produced during the design development phase will identify issues, suggest alternatives, and recommend the approach. Some of the issues are technical, and some are required by regulation. However, many are operational issues and the detailed definition of the ATC system will depend on the finalization of the CHSTP Operating Plan.

3.4.1 General

- The ATC system specification must provide functional requirements and performance thresholds. It must be flexible and not mandate particular systems, devices and methods.
- ATC system interfaces with other systems as well as with the infrastructure and services must be clearly defined, especially those across contractual boundaries.
- The ATC system specification must preclude experimental devices, prototypes, and technology or equipment not mature, accurate, or reliable for the HST environment.

The ATC system specification must preclude a contractor from proposing a system which incorporates immature elements.

3.4.2 ATC Integration

- Close coordination with Rolling Stock, Communications, and Operations is required during the development of the ATC system criteria and specifications to ensure an integrated system
- Certain ATC system elements will reside in specific pieces of CHSTP equipment, such as on-board trains or on the wayside. Some ATC functions will be provided by distributed ATC equipment and distributed equipment of other systems.
- The ATC design team must perform integration work with the rolling stock team to ensure that sufficient ATC equipment space and power are provided, and that details for key components are accommodated. For example, particular types of tachometer (e.g., axle end) should not be precluded by the rolling stock body and truck design and maintenance requirements

The location of the equipment in which certain ATC functions reside depends to some extent on the architecture of each ATC Supplier. To the extent possible, the ATC system specification will allow flexibility to the ATC supplier to propose the most cost-effective solution that provides the required overall ATC system functionality, performance, safety, availability, and reliability.

3.4.3 Determination of Position and Speed

- The wayside ATP subsystem will use track circuit occupancy to determine train position. The on-board ATP subsystem must have higher resolution of speed and position, since it uses these to accurately control and supervise train movement. The higher resolution is necessary so the train can travel through a block as fast as safely possible, can be operated in accordance with civil speed restrictions that may not be limited to track circuit boundaries, and so the train can stop before it moves past its Movement Authority limit.
- Safe, accurate, and reliable determination of position and speed is one of the most critical functions of an ATC system. Speed and position determination are typically done using a combination of devices and techniques, including tachometers, inertial sensors, GPS, and transponders or balises (mounted between the rails on the track).
- Wayside track circuits indicate the position of a particular train on the track. The position information is used to fulfill the interlocking functions and to protect the train from other trains.
- Movement Authority limits are established as part of a Movement Authority for a specific train. These limits define the target point, the location on the track beyond which the train cannot safely proceed, and the maximum speeds along the track that the train can go between its current position and its target point.
- Each train's on-board ATP equipment set must receive its Movement Authority from the wayside ATP equipment. The ATP subsystem bases the Movement Authority on factors including the status of routes through interlockings, the position of switches, occupancy of track circuits, location of other trains, and other elements of the wayside signal system and relate them to the on-board database.
- On-board ATC equipment databases must also allow for updates from the ATS OCC equipment, for the temporary modification of database elements including speed restrictions.
- The train ATP equipment must determine its position in relation to the database and compare its actual speed with the allowed speed at its current track position.
- The Train Operator's display must provide sufficient information to allow the Train Operator to control the throttle and brake so the train speed is close to the speed limit, without unnecessary automatic ATP equipment intervention for impending or even actual overspeed.

On-board ATP speed and position sensors must be proven products and must be applied, combined, and processed so the on-board ATP equipment's estimate of speed and position is adequately accurate to ensure train safety. This may require diverse means of obtaining and processing speed and position data.

Although rolling stock propulsion or brake subsystem tachometers may be used by the ATC system for non-vital functions, the primary safety-critical function of determination of train position and speed will use sensors provided and installed by the ATC system supplier.

3.4.4 Hardware Requirements for Various Subsystems

The ATC system design must resolve the following ATC system hardware issues;

- Rolling Stock Tachometers; Rolling stock tachometers will be mounted on the axle ends or on gearboxes. Similar devices are also required by the train propulsion and brake systems for operation and for slip and slide control. These devices generate pulses as the axles rotate; connected equipment converts the pulse into distance traveled. The speed and distance measurements are subject to errors from wheel wear, wheel slip, and wheel slide. Such errors occur despite the wheel slip and slide protection provided in the

propulsion and braking subsystems. The signal system supplier will provide dedicated tachometers which will be installed in locations provided by the rolling stock supplier, as defined in a detailed interface definition.

- Wayside Transponders; Transponders, where deployed, will be mounted between the running rails; each one provides a set of fixed or variable data to the train when a transponder interrogator mounted under the train passes over the transponder. The on-board ATP equipment uses the data received from the transponder to correct any accumulating positioning error in the on-board ATP subsystem. The error is generally due to slip and slide between the wheels and the rails. The on-board ATP subsystem continuously assesses the worst case for error accumulation and takes account of it in enforcing Movement Authority limits. Transponders are called balises in the ERTMS system specifications. The Eurobalise works reliably at 200+ mph to ensure that the required amount of data capable of being held and transmitted by the balise can be received by the train.
- Other devices
 - GPS is being used to help determine location by some PTC systems, in conjunction with tachometers. The use of GPS as a prime component of position determination in a vital signal system will be challenging. There are limits on GPS signal availability, for example when a train is operating through tunnels or in city areas with tall buildings that can block satellite reception.
 - Inertial navigation systems, although proven in aerospace applications, have little experience on railroads. Such devices incrementally sum accelerations in the three axes to determine velocity, distance, and direction moved. They are subject to errors from train suspension effects and accelerations caused by discontinuities in the track.
 - One supplier has developed a laser optical sensor to measure distance traveled and actual speed with high accuracy. Although tested in a limited fashion on main line locomotives, the devices have been placed in revenue service on a transit application with a maximum speed of 50 MPH. Such devices are considered to be experimental and not fully mature in the railway environment. Any device using sensitive electronics and optics is likely to have reliability problems operating in the high shock and vibration and dirty environment around the truck and underside of a train. No optical device has been placed in service at high speeds.

On-board ATP equipment can determine speed from some of the same devices, as described above. Tachometers, inertial devices, and GPS can determine speed very accurately when used in combination.

Position determination using GPS would likely be in combination with tachometers and other on-board devices. Some development will be required however for a supplier to demonstrate in the system safety analysis that the specified criteria for reliability, availability, and safety can be met by the incorporation of GPS and other integrated devices. GPS receivers will likely be used to determine time for the system to ensure that safety-critical data received from the wayside and central office is current.

3.4.5 Types of Data Transmission from Transponders

The ATC system design must resolve the following issues with the data that will be transmitted to trains from the transponders;

Transponders can be of two basic types; the first contains fixed data which is transmitted to trains as they pass over the location; the transponders have no electrical connection to any other ATC element. The second contains variable or fixed and variable data, and the connection to another ATC system element alters the transmitted data. For example, different speed limits can be transmitted if the switch ahead is in the normal or reverse position.

- The fixed data can simply be a unique location identification which the train ATP equipment compares to its database. The ATP equipment uses the data to correct the accumulated error in its calculation of its position.
- The fixed location identification data provides an absolute confirmation of the train's position. The on-board ATP equipment can use this as a diverse confirmation of train position. It can provide a positive confirmation of position if the train is operated under procedure through a switch with unknown status during failures. This is preferred to a Train Operator data input confirmation, as it enhances safety during failure conditions. These diverse data uses help the ATC system achieve the required safety level.
- The fixed data can include speed limits which are transmitted to the on-board ATP equipment. However, the present design intention is that speed limit data will be in the on-board database and transponders will not upload this information.
- Variable data can include the locations of trains and status of switches and routes in front of the train.

An ATC system with transponder-only data transmission to trains can only provide intermittent ATP commands or Movement Authorities. This type of ATC system has performance and functional constraints when compared to an ATC system with continuous communication of Movement Authority data. The CHSTP ATC system will be a continuous communication system, and will receive Movement Authority data either via a radio link (such as with ERTMS) from wayside equipment or via a digitally encoded track circuit transmission using the track circuits and running rails (e.g., TVM430, Shinkansen, etc.).

The ATC system design plans to use transponders for either radio or coded track circuit transmission, to provide the position error correction function for the on-board speed and location ATP subsystem.

3.4.6 Location of On-Board ATC Equipment

- ATC equipment will be mounted on the rolling stock. These include Train Operator displays; the ATC controller; ATC communications equipment; ATP subsystem location determination equipment (tachometer, GPS, inertial navigation, transponder reader antennas, etc.); data radios; and antennas for GPS and data radios.
- Much of this equipment is unique to specific ATC suppliers; it should be supplied by the ATC supplier not the rolling stock supplier.
- The interface between the train subsystems and the on-board ATC equipment is substantial.

The CHSTP Systems team will coordinate between the ATC, communications, rolling stock, and operations personnel to discuss the equipment required and to provide in the rolling stock design for;

- physical space requirements
- mounting provisions
- cables and cableways to connect the equipment
- termination panels
- power and ventilation needs
- other considerations including non-metallic panels around radio and GPS antennas

3.4.7 ATC Safety Requirements

The ATC system will be subject to an overall safety requirement. The CHSTP Systems engineers will establish a safety program covering the ATC system and its subsystems. The ATC safety program will allocate safety targets to individual equipment items and subsystems. The CHSTP Systems engineers and ATC supplier will perform ATC safety program tasks.

The ATC supplier will perform specified safety program activities, including planning, analysis, and reporting. Analyses will include Preliminary Hazard Analysis, Fault Tree Analysis, Failure Modes, Effects and Criticality Analyses (FMECAs) of train control components, Operating Hazard Analysis, Subsystem Hazard Analysis, Sneak Circuit Analysis, and Hazard Resolution Report.

The CHSTP Systems Engineer will work with the ATC supplier to prove and document that ATC software and data with safety-critical functions or responsibility are developed, tested, integrated, maintained, loaded, installed, updated, validated, verified, and documented in a structured, documented program that is acceptable to CHSTP. The specific means of achieving safety-critical software will not be specified as there are multiple industry-accepted means of achieving this.

Careful consideration will be given to the potential ATC suppliers' proposed methods for achieving safety-critical software. Several train control projects have suffered delays in recent years even with established systems. The ATC suppliers' proposed methods will be reviewed and accepted if appropriate.

To achieve safety-critical software, the CHSTP will specify proven systems and only accept suppliers with a proven capability to provide the needed structured development environment. CHSTP will target a minimum of new or changed functions in order to minimize the risk to schedule and budget posed by software development risks.

The ATC safety requirements will include the need to develop a set of safe braking criteria that will be described as part of a model. This safe braking model will define the necessary criteria that the ATC and Rolling Stock systems design must meet in order to satisfy the safe separation of trains, enforcement of home signals, and enforcement of speed limits.

The system design will include the ability for the ATC subsystem to command both a controlled emergency brake in which wheel slide protection is active, and an absolute emergency brake in which wheel slide protection is cut out.

3.4.8 Reliability, Availability, and Maintainability of the ATC System

The ATC system must have extremely high availability to avoid delays caused by ATC system, subsystem, and equipment failures. Different degrees of redundancy are appropriate for different portions of the ATC system to achieve availability targets and minimize the failure rate and the mean time to repair.

The CHSTP Systems team will set up dialogue between ATC design, ATC and computer maintenance personnel, Operations, and system safety personnel, to determine and specify the acceptable levels for these targets.

The ATC supplier will perform specified reliability program activities, including planning, analysis, and reporting. Analyses will include reliability allocation, historical reliability analysis, availability and reliability prediction, and an availability and reliability Demonstration.

3.4.9 Data Radio Requirements

The ATC system will include high speed, high availability data radio equipment and links, with comprehensive and likely overlapping coverage throughout all main line and Yard tracks.

Radio alternatives will be investigated by the Systems team for applicability (performance, coverage, availability, etc.) of the frequencies and bandwidth. Existing and emerging public

standard systems will be considered. This will be done with the communications group working closely with the ATC group.

3.4.10 ATC Requirements on Common Corridors

The extent of shared use operation on the LOSSAN and Caltrain corridors has yet to be finalized. The Caltrain corridor must operate with an FRA-approved PTC by the end of 2015. 49CFR236 Subpart I also mandates interoperability between any two PTC systems whose locomotives interoperate. The host railroads (those that own the tracks in a particular location) must define and procure the wayside PTC system, and make suitable arrangements with tenant operators on the line.

The CHSTP approach to ATC definition is to focus on the ATC system outside the common and shared use corridors. The ITC PTC system, which is likely to be used by potentially interoperating railroads, has not yet been defined to the degree required to achieve interoperability. Therefore it is not possible to determine if the ITC PTC system can meet the CHSTP safety, functional, and performance requirements. The prime qualification for the CHSTP ATC system is that it has operated in revenue in a similar environment and at the speeds targeted (up to 250 mph).

The ITC PTC system will be based on an existing product, with significant changes now being made to meet the detailed requirements of the Class 1 freight railroads, including a new wireless network system and radio hardware. It is unlikely the ITC PTC can serve as the CHSTP ATC system.

The feasibility of CHSTP trains and other trains to operate on the same tracks, including Caltrain and other regional commuter train tracks, can only be fully addressed after the ITC PTC system is fully developed. Consideration will be given then to interoperable operations including the interoperability between CHSTP ATC and ITC PTC systems, the dual equipping of shared wayside territory, or the dual equipping of trains such that the operational and safety criteria of all affected rail operators can be met.

3.5 INTERFACES

The ATC system will have interfaces to the following subsystems.

3.5.1 Rolling Stock

There will be significant mechanical, electrical and logical interfaces between ATC and the rolling stock. The specifics will depend on the final requirements of functionality. For example, ATO operation is currently planned. It has not yet been decided whether correct side door interlocking is required. If so, this function would be coupled with a berthing function that would prevent doors being opened unless the train is correctly stopped within the limits of a platform. These functions would entail specific interfaces to be defined and detailed at both the bid specification and procurement stages.

As Rolling Stock is likely to be procured separately from the ATC system, a significant amount of detail must be agreed such that the Rolling Stock side of the interface can be included in the scope of the procurement.

3.5.2 Communications

Interfaces between the ATC system and the Communications system are extensive. If an ERTMS train control system is selected, data and voice radio communications will be integral with the overall ATC subsystem.

3.5.3 Traction Power

The ATC track circuit bonding and grounding must be compatible with the needs of the traction power subsystem.

3.5.4 OCS

It is anticipated that the ATC system may be required to implement two functions;

- On-board commands to the Rolling Stock equipment to isolate between section gaps as the train traverses the gap. This can be driven by a database function where the section gaps are identified in the on-board database
- Prevention of trains entering sections of the line where the OCS has been de-energized. This will require an interface between the OCS energized indication and the ATC system. This could be done at the OCC level with an interface between ATS and SCADA, or at a local level. Modified movement authorities would be transmitted to the on-board ATC and a stop enforced.

3.5.5 Track

The details of the track layout including switch configurations, gradient, curvature, etc. must be included in the safety-critical ATC database. There will also be physical interfaces between the switch machines and the switches themselves, between the track and ATC transponders where the latter must be securely fixed to the track and maintained within strict tolerances, and cable bonds to the track for track circuit and traction power supply continuity.

In the Yards, derails and other devices used for stop signal enforcement must also be fixed to the rails requiring an interface definition.

3.5.6 Infrastructure

The ATC system interfaces with infrastructure for installation of equipment houses, cases, signals, and other elements along the right of way, and to comply with clearance requirements and access to the various ATC facilities. Basic footprint, equipment size, and access needs have been provided to the infrastructure group.

Special considerations have been given to tunnel portals for the need to house ATC equipment in buildings and other structures at these locations.

3.5.7 System Time

The ATC system will derive its time standard from received GPS signals.

3.6 APPLICABILITY TO U.S. STANDARDS

There are several sets of standards that can be applied to the ATC system. However, some aspects of standards including the AREMA Manual of Recommended Practices for Signaling and Communications may preclude service-proven systems that were designed to Euronorms or other foreign standards. Where possible, equivalency will be demonstrated. In some cases the Euronorm will be accepted as an applicable standard in the specifications.

Even though technical equivalency may not be able to be fully demonstrated, there is a need to demonstrate an equivalent level of safety.

4.0 SUMMARY AND RECOMMENDATIONS

In summary the ATC system will consist of the elements described in this Technical Memorandum. The ATC system must be proven in a high speed (200 MPH plus) environment with a minimum of modification to comply with CFR Regulations and with technical issues such as available frequencies and bandwidth.

Wayside signals will be kept to a minimum and provided only at interlockings and in yards.

ATO mode functionality will be provided as described. ATO mode will be available on the main lines and on transfer tracks between Yards and the Main Lines. ATO mode will not be available within any yard.

Yard train movements will be authorized by wayside signals which will be enforced.

The ATC system will enforce speed limits both temporary and permanent when in full ATC modes and in Yard and Restricted Manual Modes. The Rolling Stock subsystem will enforce the speed limit as prescribed by 49CFR236 Subpart I when the ATC on-board system is bypassed.

The ATC system specifications will be written for functionality, performance, and system assurance (Reliability, Availability, Maintainability, and Safety (RAMS)). The ATC system specifications will not specify a particular product or architecture.

The PTC functional requirements of the RSIA will be specified. Because of many unknown elements including the extent of interoperation of trains on common corridors and details of the ITC PTC currently under development by the freight railroads, the CHSTP ATC system will continue to be developed without specifying direct interoperability with ITC.

5.0 SOURCE INFORMATION AND REFERENCES

- AREMA Communications & Signals Manual of Recommended Practice
- 49CFR Part 229
- 49CFR Part 236

6.0 DESIGN MANUAL CRITERIA

6.1 INFORMATION FOR INCLUSION IN DESIGN MANUAL

The CHSTP Project requires the deployment of an ATC system that supports the performance goals of the project including maximum speeds, trip times, and headway and that meets various sets of federally mandated practices and functions for a signaling system including Positive Train Control (PTC). The ATC system must ensure the following key safety functions;

- Safe train separation
- Prevention of overspeed derailments
- Fail safe train detection
- Broken rail detection
- Interlocking rules enforcement
- Hazard detection system responses
- Work zone protection

The overall ATC system must incorporate the functional areas of Automatic Train Protection (ATP), Automatic Train Supervision (ATS), and Automatic Train Operation (ATO). These three functional areas of the ATC can be briefly defined as;

- ATP – Automatic Train Protection – The functional set responsible for the safety-critical functions including those of interlocking, train detection, signal aspects, broken rail protection, hazard detectors (if implemented as part of the ATC system), and movement authorities (including speed limit and cab signal commands if appropriate) that are sent to the train and acted upon by the on-board train control to enforce safe limits. The ATP functional set includes the enforcement of the safety-critical functions. PTC functions are part of ATP.
- ATO – Automatic Train Operation – The functional set responsible for the automatic operation of throttle and brake commands to move trains between stations and other stopping locations (including those required due to the proximity of other trains and signal status) within the constraints imposed by the ATP functional set. Provides dwell timing at stations and the control or prompting of the opening and closing of train doors.
- ATS – Automatic Train Supervision – The functional set within the automatic train control system that is responsible for the centralized supervision and control of train movements; the ATS monitors trains, adjusts the performance of individual trains to maintain schedules, and provides data to adjust service to minimize inconveniences otherwise caused by irregularities. ATS also provides automatic route setting at interlockings and the identification and tracking of trains, the display of alarms and events, and logging and storage of event data.

In consideration of the requirements of the signaling related sections of the Code of Federal Regulations (CFR) to provide a proven means of detecting possible broken rails, CHSTP will specify track circuits. This makes the European led radio based train control system; ERTMS Level 2 a strong contender for the train control technology for the following reasons;

- ERTMS Level 2 uses track circuits as a primary train location subsystem
- It has been widely deployed on high speed rail routes in Europe and other countries and is therefore an in-service proven system
- It has been deployed on systems with similar maximum speeds and headways as CHSTP design goals

- There are multiple suppliers of hardware and software; these suppliers have subsidiaries in the United States

The definition of an ERTMS system includes the train control data and operations voice radio communication between the wayside and the trains. The EIRENE (radio) component of ERTMS operates in the GSM bandwidth that has been dedicated throughout Europe for railway operations (GSM-R (Railways)) and carries both voice and train control data circuits. There is no GSM-R frequency band dedicated to railroad operation in the United States. If an ERTMS-type system is to be deployed on CHSTP and channels in the appropriate frequencies cannot be secured from the FCC, the system will require adaptation with respect to data and voice radio communications.

Other proven ATC systems that possibly meet the high speed experience criteria include the TVM430 coded track circuit based system (originally developed by CSEE, now a division of Ansaldo) and related products that are based on coded track circuits, and Japanese coded track circuit technology deployed on the Shinkansen and Shinkansen derivative lines in Japan and other countries including Taiwan.

ERTMS and coded track circuit type systems have significant differences; ERTMS detects train position using track circuits but conveys safety-critical information to trains in the form of movement authorities by means of a data radio network. Coded track circuit type systems detect train position using track circuits but also send data to trains through the track circuit (running rails) similar in concept to the way in which conventional cab speed signals systems have worked for many years. The latest digital track circuits allow for much higher data rates (than conventional cab signaling circuits) allowing messages to be sent to trains in real time and convey much more information than the traditional maximum speed limit.

To take advantage of the two general types of ATC system (coded track circuit and radio network based) with high speed rail proven experience, the design criteria will address an ATC system specification that focuses on function and performance and allows coded track circuit or radio based systems to be proposed.

This Technical Memorandum describes the functions within each of the ATC subsystems; ATP, ATO, and ATS; and identifies how these functional subsystem requirements will be developed and met by the train control design, specification, and implementation phases.

The prime requirement for the train control system to be used on the CHSTP system is that the technology must already exist as part of an operating system with proven experience worldwide on at least one high speed passenger railway.

Any candidate technology must also meet or be modified to meet the regulatory requirements from authorities including FRA, FCC, and CPUC.

6.2 GENERAL INFORMATION

6.2.1 Definition of Terms

The terms listed below are train control relative definitions and acronyms. A complete glossary of design terms, abbreviations and acronyms used by the Project are contained in Technical memorandum TM 0.0.a; Design Terms, Abbreviations, and Acronyms.

Absolute Block - A section of track on which a train is not permitted to enter while it is occupied by another train.

Automatic Train Control; (ATC) The collective name for the train control subsystems that typically comprise the Automatic Train Protection, the Automatic Train Operation, and Automatic Train Supervision sets of functions that govern train operations on the main lines.

Automatic Train Control Bypass; A state in which the ATC system is bypassed under failure conditions that allows the train to be operated manually at speeds that are mandated by operating procedures.

Automatic Train Control Main Line Territory; Territory equipped with ATC wayside equipment with full ATP functionality.

Automatic Train Control Yard Territory; Territory equipped with ATC wayside equipment in the Yard areas.

Automatic Train Operation; (ATO); A mode of operation for onboard train ATC equipment used to move the train to the next station under ATP supervision.

Automatic Train Protection; Those functions within the ATC that ensure safe train separation, preclude overspeed operation, and preclude operation outside of safe limits (e.g. over an improperly set switch).

Automatic Train Supervision; (ATS) Those functions within ATC that are for train dispatching and allow the monitoring and controlling (both manual and automated) of operations and traffic on the railroad.

Dwarf Signal A low wayside signal with minimal preview as opposed to a high signal that is used to provide adequate preview of the aspect displayed to high speed trains.

GSM-R: The radio version of the Global System for Mobile communications (originally from Groupe Spécial Mobile) used on railroads for control system in Europe and possibly to be adapted for CHSTP

Guaranteed Emergency Brake Rate: The minimum emergency brake rate achieved under the range of environmental conditions and brake equipment failure modes which can normally be anticipated to exist on the CHSTP system

Headway: The time between buses, trains, or other transit vehicles at a given point. For example, a 15 - minute headway means that one train arrives every 15 minutes.

Home Signal – A fixed signal (wayside or virtual) at the entrance of a route to govern trains entering or using that route.

Impedance Bond: An electrical device located between the rails consisting of a coil with a center tap used to bypass insulated joints in order to prevent track circuit energy from bypassing the insulated joint while allowing the traction return current to bypass the insulated joint. The center tap can also be used to provide a connection from the rails to the static wire and/or traction power facilities for the traction return current.

Insulated Joint: A joint in the running rail used to prevent track circuit energy on one side of the joint from leaking to the other side of the joint.

Interlocking An arrangement of signals (wayside and/or virtual) and switch appliances so interconnected that their movement must succeed each other in proper sequence and for which interlocking rules are in effect.

Interlocking Signals Fixed signals which govern the movement of trains through Interlockings that are observed by the train operator under ATC failure conditions at reduced speed.

Interoperability: In the context of the European High-Speed Lines, is the ability of the European High-Speed lines railway network to allow high-speed trains to run safely and

continuously with the specified performances. It is based on the whole of the legal, technical, safety, and operational conditions that must be fulfilled to satisfy the necessary requirements. Thus, for example, a German high-speed train satisfying the requirements of the Rolling Stock Technical Specification for Interoperability (TSI) is able to run safely and continuously on a French high-speed line of which the infrastructure is satisfying to the different requirements of the different infrastructure Technical Specifications for Interoperability. These TSI design standards were developed specifically for the design, construction and operation of interoperable high-speed railways in Europe and are based on European and international best practices.

Intrusion: An errant vehicle's exit out of its right-of-way and entry into the operating space of another transportation system's right-of-way.

Intrusion Detection: An electronic system that alarms the intrusion event to the Central Control and to the Train Operators. A dedicated detection system may be used for non-vehicular intrusion such as for people or animals.

Main Line: The tracks allocated to the high-speed train traffic at normal commercial speed and not normally used for switching or storage.

Movement Authority: The vital information used by the on-board ATC system to determine the position on the track (or limit) to which it can safely move under ATC supervision, including the speed limits both permanent and temporary that must be observed between its current position and the Movement Authority limit.

Non-Vital: A designation placed on a system, subsystem, element, component, or function denoting that satisfactory operation of such is not mandatory for safety.

Operations Control Center (OCC): A centralized control facility from which railroad operations are supervised and controlled. The main control center can be supported by Regional Control Center(s) from where specific regions or branches of the system can be supervised and controlled and that can act as a back-up control facility in the event of a failure of the OCC.

Positive Train Control (PTC): A proactive train control system that prevents train collisions, derailments due to overspeeding, and protection of work zones on or about the tracks.

Radio Frequency: The frequency range of the electromagnetic spectrum that is used for radio communication.

Rail Safety Improvement Act (2008): An Act of Congress that mandates the implementation of Positive Train Control on certain rail lines (including those over which passenger trains operate) by the end of 2015

Regional Control Center (RCC): A control facility from which a specific region of the CHSTP is supervised and controlled. The RCC can act as a back-up control facility in the event of a failure of the OCC.

Restricted Manual: A mode of operation under wayside signal and procedural protection with train speed limited by the on-board ATC equipment.

Restricted Speed: Operation at no greater than twenty (20) miles an hour, prepared to stop within one half (1/2) the range of vision.

Shared Right-of-Way: A CHSTP alignment where high-speed trains operate in proximity to other transportation systems, including conventional passenger railroads and freight railroads, without sharing tracks. Also includes highways.

Shared Use Corridor: A CHSTP alignment where high-speed trains operate with other passenger and freight railroads (e.g., Caltrain, Metrolink, Amtrak, UP, and BNSF) and share the corridor.

Shared Use Track: Segment along the CHSTP alignment where high-speed trains operate with other passenger and freight railroads, (e.g., Caltrain, Metrolink, Amtrak, UP and BNSF) on the same tracks.

Signal Aspect: The appearance of a fixed signal conveying an indication as viewed from the direction of an approaching train; the appearance of a cab signal conveying an indication as viewed by an observer in the cab. Flashing or lack of flashing of a light is a part of the aspect.

Signal Block: A length of track of defined limits, the use of which is governed by the ATC system; a Signal Block may include one or more Track Circuits.

Signal Indication: The information conveyed by a signal aspect.

Track Circuit: A method of determining occupancy of a section of track and/or a broken rail by sending an electrical signal down the track from the transmit to the received end of the section of track and indicating that the section of track is complete and not occupied by detecting a minimum level of the proper signal at the receive end.

Train Operator's Display: An indication in the Train Operator's cab that provides the status of the ATC system and the safe limits within which the train may operate

Virtual Signal: A database element that replicates the function of a wayside signal in the ATC system but with no physical signal installed at the wayside.

Vital: A designation placed on a system, subsystem, element, component, or function denoting that satisfactory operation of such is mandatory for safety.

Wayside Signals: Devices located along the right-of-way for providing information to the Train Operators relative to train operations as opposed to the cab signal displays that are located within the control compartment of the rolling stock.

Yard Signal System: The train control system that controls safe train movements within the limits of Yard Tracks.

Yard Track: A section of track used for storage of trains that is auxiliary to the main track and not used by trains that are carrying passengers. Refuge tracks at stations are yard tracks. Yards consist of more than one yard track used for storing trains, inspecting trains, and accessing maintenance facilities. Yard tracks may or may not have track circuits on them.

Yard Transition Tracks: A section of track used for the transition of trains between the main lines and Yard Tracks. Transition Tracks are equipped with both the main line ATC system and the Yard Signal System. Yard transition tracks shall be track circuited.

6.2.2 Acronyms

Several acronyms have different definitions depending on the technical area in which they are used. The following list is of acronyms identified thus far by the CHSTP.

A

ATC	Automatic Train Control
ATO	Automatic Train Operation
ATP	Automatic Train Protection
ATS	Automatic Train Supervision

C

CTS	Communications Transmission System
-----	------------------------------------

D

DCS	Data Communications Subsystem
-----	-------------------------------

E

ERTMS	European Railway Traffic Management System
ETCS	European Train Control System

F

FCC	Federal Communications Commission
FRA	Federal Railroad Administration

G

GPS	Global Positioning System
GSM-R	Global System for Mobile Communications - Rail

O

OCC	Operation Control Center
OCS	Overhead Contact System

P

PTC	Positive Train Control
-----	------------------------

R

RCC	Regional Control Center
-----	-------------------------

S

SCADA	Supervisory Control and Data Acquisition
-------	--

T

TCC	Train Control and Communications
-----	----------------------------------

6.2.3 Units of Measurement

The California High-Speed Train Project is based on U.S. Customary Units consistent with guidelines prepared by the California Department of Transportation and defined by the National Institute of Standards and Technology (NIST). U.S. Customary Units are officially used in the United States, and are also known in the US as “English” or “Imperial” units. In order to avoid confusion, all formal references to units of measure should be made in terms of U.S. Customary Units.

6.3 ATC DESIGN CRITERIA

The overall term used to define the train control system used in main line territory (i.e. not Yard tracks) is Automatic Train Control (ATC).

6.3.1 ATC Functional Groups

ATC shall be divided into three functional areas:

- **Automatic Train Protection (ATP);**
The subsystem within the automatic train control system that maintains fail-safe protection against collisions, excessive speed, and other hazardous conditions through a combination of train detection, train separation, and interlocking.
- **Automatic Train Operation (ATO);**
The subsystem within the automatic train control system that performs any or all of the functions of speed regulation, programmed stopping, door control, performance level regulation, or other functions otherwise assigned to the train operator.
- **Automatic Train Supervision (ATS);**
The subsystem within the automatic train control system that monitors trains, adjusts the performance of individual trains to maintain schedules, and provides data to adjust service to minimize inconveniences otherwise caused by irregularities. ATS also provides the means by which switches are aligned and signaled routes are set and cleared both automatically and by manual input.

The ATC system shall also be subdivided into physical subsystems; each subsystem contains differing sets of functions drawn from the above three functional groups. The physical subsystems are as follows;

- **Wayside** – consists of equipment located in housings along the right of way including station equipment rooms, train control equipment houses, and signal equipment cases and cabinets. The equipment includes track circuits, switch machines, wayside signals, interlocking equipment, and transponders (or balises), much of which is considered to be conventional signal system equipment. This equipment includes ATP electronics that is either integral with or interfaces to the track circuit and interlocking equipment and to other sensors including intrusion, seismic, and other detectors that will allow the train control system to react to an event and bring the train to a safe speed if necessary. The ATP processors obtain track circuit occupancy status, interlocking route status, and sensor device status in order to output messages to the trains that define the safe limits (including distance to go and target speeds) for train movement. Equipment will be housed in a distributed fashion along the rail line to provide continuous coverage including on aerial structures, in tunnels, yards, and stations.

Interlocking functions including route setting, route locking, approach locking, and sectional release will be performed by wayside microprocessor interlocking equipment.

The wayside subsystem will be linked by the data communication subsystem to allow supervision and remote control from the Operations Control Center (OCC).
- **On-board** – This subsystem consists of equipment located on the passenger trainsets and maintenance vehicles and includes processors, firmware, software and electronics, operator displays, operator switches, data radios and antennas, transponder/balise antennas, code pick-up antennas, network components, GPS receiver and antennas, tachometers and other sensors, and all connections between train control elements and interfaces between train control and the train subsystems including propulsion and brakes. Sensors and processors are used to determine position and speed, computer equipment, and operator controls and displays. Depending on the train control technology selected, the on-board equipment may also include data radios and antennas

with which to communicate with the wayside and central control subsystems. The on-board subsystem may also include antennas and decoding equipment to detect digital signals transmitted to the train through the rails. The on-board package will receive data through the radio or the rails that define the movement authorities within which the train can safely operate. The actual speed of the train will be continuously compared to the authorized speed. If the train is to operate in ATO, the ATO functional set will handle any changes in speed called for. If the train approaches an overspeed condition the ATP functional set will generate a warning to the train operator. If appropriate action is not taken, the on-board system will intervene to ensure that the train movement stays within safe limits.

The on-board ATC will use sensors to determine the train's position to a high level of resolution both laterally (which track the train is on) and longitudinally, as well as accurately measure speed. The enforcement of the Movement Authority limits enables the on-board system to provide the required PTC protections.

The onboard ATO functional set will regulate train performance when selected. Commands received from the ATS functional set may also provide for pacing trains at a lower speed than their maximum speed or increasing speeds from the pacing speed called for by the normal schedule. Under no circumstances can these ATO functions allow the train to operate faster or further than the safety-critical limits determined by the PTC functions of the ATP functional set.

The on-board ATC subsystem will interface with the rolling stock subsystems to support the ATP, ATO, and ATS functional sets.

In addition to interfaces required for the ATC system functions, additional train interfaces will provide remote monitoring capabilities of rolling stock subsystems. Remote monitoring allows for early diagnosis of trouble. Monitoring can be done using the office subsystem as part of the ATS functional set. Alarms and event indications can be displayed at the Operations Control center and the Regional Control Centers, or at ATS remote workstations at other locations.

On-board passenger information systems, including audible and visual announcements of real-time performance and other information to the passengers may be provided from the Office subsystem through the ATC data communications subsystem or by an independent data communications subsystem.

The on-board ATP functional set equipment will interface to wireless or above-rail inductive antennas that receive Movement Authority commands from wayside ATP functional set equipment. A data radio subsystem will provide data transmission between the train and wayside.

- **Data Communications Subsystem (DCS)** – Communicates data, commands, indications and alarms between ATC subsystems and locations. This consists of connected networks of wireless, fiber optic, and hardwired equipment.

The DCS will carry both safety-critical and non-safety-critical (management) information. The DCS itself does not have to be a safety-critical system. Coding and other techniques in the other ATC subsystems ensure that the data received is of sufficient integrity and currency that it can be treated as accurate for safety-critical applications. ATP equipment will reject any safety-critical data that cannot be validated.

Many DCS elements, including electronics, fiber cables, radio equipment, and antennas will be on CHSTP property. However, the diversity that may be needed to deliver the specified communication link availability may require the use of leased communications lines provided by a third party as backup to the primary links. Some radio antennas may also be located off CHSTP property where propagation considerations indicate a benefit.

The candidate ATC system ERTMS uses 900 MHz GSM-R radio to communicate movement authorities and safety-critical data between train and wayside. Possible use of GSM-R in the U.S. is being reviewed by CHSTP Systems Group, as well as alternative

frequency bands, including the use of Long term Evolution (LTE) wireless network technology.

- **The Office** subsystem supports the majority of the ATS functional sets. It consists of a centralized or a distributed computer control system with dispatcher workstations that provides the overall CHSTP train operation management functions including remote routing and supervision functions. It includes announcements of events including critical alarms and a logging capacity for all events. It generates many system performance reports. Many ATS functions supported by the Office subsystem are automated, including setting of routes at interlockings, regulation of train movements in accordance with the schedule, and the recovery of the service from interruptions and failures.

At any time, dispatchers can take manual control of route setting and schedule regulation functions from their ATS workstations, in accordance with the rail management plans and procedures.

The Office subsystem architecture can be centralized or distributed to provide reliable computing power and the required workstations that allow supervisors to dispatch the services, monitor subsystem performances, and intervene to manually supersede automated processes in the event of incident and emergency. The territory controlled by each workstation can be adjusted by users and/or administrators to adjust to workload demands as they fluctuate. As workstations can be in a centralized facility and at remote locations, the ATC system can support a flexible approach to the overall supervision of the CHSTP rail operations.

The Office subsystem communicates with wayside locations, remote workstations, trains, other ATC elements, and sensors including intrusion, through the data communications subsystem.

- **Field Portable** – Equipment for use by Employees in Charge (EIC) of wayside work; used to manage track and other wayside systems access. EIC portables will communicate digitally and wirelessly with the ATS and with on-board ATC subsystems to control train movements through a work zone. Trains may only operate through established work zones with the agreement of the EIC who can use the field portable equipment to enforce reduced speeds and track blocks. Although generally maintenance work on the tracks will be done outside of revenue hours, EIC portables will protect all worksites and zones on or about the track, from movements of ATC-equipped maintenance vehicles and passenger trains.
- **Yard** – Equipment distributed throughout the yards and maintenance facilities for the operation of switches, and to provide wayside illuminated signals, and enforcement devices to control trains movements within Yard territory. Red signal aspects shall be enforced such that trains cannot pass a signal displaying a stop indication and cannot enter an unlocked switch or stop foul of a train movement authorized on another track.

Control of the Yard signaling systems shall be from a panel or workstation located in a control room (or tower) within the yard facility.

Train movements between yards and the main line shall be routed through transition tracks where trains will transition between ATC and Yard signal system modes of operation.

6.3.2 Positive Train Control (PTC)

The ATC system for CHSTP shall include the functions of Positive Train Control (PTC) that shall meet the objectives of PTC as defined by the Rail Safety Improvement Act of 2008. For CHSTP, PTC shall be an integrated set of functions within the ATC system where train collision and overspeed protection as well as the protection of roadway workers shall be enforced. Although many "PTC" systems are being implemented as overlays on conventional wayside signal systems in order to meet the RSIA deadline of the end of 2015, PTC for CHSTP shall be an integral part of the ATC system.

For high speed operation, the safety of the train must be assured by an automatic system that enforces speeds at all times including the slowing of a train for an obstruction of the line ahead. Such obstructions can include a train ahead, a reduction in the civil speed limit (permanent and temporary), and an unset or unlocked switch in an interlocking ahead of the train.

The basic safety-critical functions of the ATP portion of an ATC system are as follows;

- Enforce all speed limits on a train to prevent overspeeding through curves, switches, work zones, and other features that require speed supervision and enforcement to ensure safe operation.
- Ensure trains are separated to avoid rear end and side swipe collisions.
- Prevent derailments and collisions from movements through incorrectly set and/or unlocked switches and from conflicting train movements by setting and locking switched routes through an interlocking and only authorizing safe train movements through the interlocking

6.3.3 Interface to Event Detectors and ATC System Responses

The train control system shall also provide safe enforcement of other functions including planned responses of the overall ATC system to event detectors and sensors (provided by other subsystems) including;

- Earthquake
- Excess wind speed
- High water levels
- Excessive rainfall
- Underpass bridge strikes
- Landslide and rock falls
- Intrusion at trackside and in tunnels
- Intrusion from overhead bridges and at tunnel portals
- Intrusion at stations
- Dragging equipment
- Rail breaks

Although the majority of the listed event sensors will be specified by other disciplines, many will be interfaced to at least one of the subsystems of the ATC, and the ATC shall invoke the system response. In some cases, the ATS subsystem shall be required to log the event and to display an event and/or an alarm to the operators, in other cases the ATP system shall be required to directly invoke a response of the train, enforcing a braking activation and possibly stopping trains in an emergency. Each sensor interface must be identified and the response of the ATC system to each interface agreed with Operations and other disciplines.

Dragging equipment detectors may need to be provided in the event that shared corridors and tracks become part of the operational requirements.

6.3.4 Broken Rail Detection

In the case of broken rail, the approach being taken is that the ATC field component shall include double rail track circuits for train detection. Track circuits are an approved means of detecting broken rails and this approach is acceptable to the FRA. A break in the rail shall cause a false occupancy in a track circuit which in turn shall result in a restrictive command to an approaching train. In order for track circuits to reliably detect broken rails and to be able to provide a level of protection to trains by means of the ATC system, the ATC system shall normally allow only one train in a track circuit at any one time.

In addition to safety-critical functions, the train control system shall also provide the train management functionality in which the effective and efficient operation of a passenger train service is assured; such functions include automated routing and scheduling of trains and a means for dispatcher intervention to deal with incidents and emergencies.

The train control system shall consist of several elements (or subsystems) that are closely integrated to provide an overall solution for high speed train operations. The train control system must be closely integrated with other system elements, such as rolling stock, intrusion detectors, and hazard detectors, to ensure the necessary level of safe operation.

6.3.5 ATC – Modes of Operation

This section describes the proposed modes of operation of trains.

The following matrix of operating modes and sub-modes has been identified;

MODE OF OPERATION	ATO OR MANUAL OPERATION	MAX TRAIN SPEED	ENFORCED BY	NOTES
ATC	ATO	Line Speed or as defined by Limit of Movement Authority	ATP	<p>This is the normal operating mode on the main line which includes automatic operation of Rolling Stock propulsion and brakes by the ATO subsystem within ATC.</p> <p>Requires an action by the Train Operator to select ATO mode. ATP system must determine that other factors are correctly set before train can move in ATO mode (Movement Authority is being received by on-board ATP subsystem, doors are closed and locked, etc.)</p> <p>Rolling Stock subsystem requirement must include the incorporation of the vigilance/alerter device to ensure The Train Operator is in the cab and alert. Rolling stock vigilance/alerter device is required in all modes of operation including ATC, RM, Bypass Yard, etc.</p>
ATC	Manual	Line Speed or as defined by Limit of Movement Authority	ATC	<p>This is the operating mode on the main line where movements and speeds are fully supervised and enforced by the ATC system but the propulsion and brakes are commanded by the Train Operator</p> <p>Vigilance/alerter function to be provided by Rolling Stock; see note above.</p> <p>CHSTP ATC may include a Call-On mode to allow the train to pass a red signal under certain controlled conditions. If so, this will be a sub-mode of ATC/Manual. To enter it, the ATC system shall send the train a Call-On command. ATP shall enforce a speed limit of 20 MPH.</p>

MODE OF OPERATION	ATO OR MANUAL OPERATION	MAX TRAIN SPEED	ENFORCED BY	NOTES
<p>Restricted Manual (RM)</p>	<p>Manual</p>	<p>FRA requirement of Restricted Speed. Restricted is 20 MPH or lower, as required to stop within half of range of vision.</p>	<p>ATC on-board subsystem</p>	<p>A degraded Mode. In this mode the On-board ATP subsystem will limit train speed to 20 MPH maximum. Train Operator will work in accordance with procedure and observe the wayside signals for authority to move. Movement authorities, including speed commands are not received in this mode. In the event of receipt of a speed command or Movement Authority from the wayside while in RM mode, the on-board ATC will automatically switch to ATC Manual mode. RM mode addresses short term ATC failures such as movement through a failed switch (under procedure) or through a failed track circuit (which can include a broken rail) outside an interlocking. Movement through an interlocking with a failed track circuit can be done under Call-On mode (see above).</p>
<p>Yard (or Depot)</p>	<p>N/A</p>	<p>Yard speed limit</p>	<p>ATC ATC shall enforce yard maximum speed limits not exceeding 20 mph as per 49CFR236 Subpart I.</p>	<p>The Train Operator will select the transition from ATC Manual mode to yard and vice versa when a train is stationary on a transition track when entering or departing a Yard. Yard signals shall be enforced however the safety criteria used in the design shall not be as restrictive as for the main line ATC system. Trains approaching a shop track from the Yard will require a Train Operator acknowledgement before being allowed to enter a shop track. Yard mode can treat a shop entrance as an end of track and further movement forward can be in RM mode. This will be considered as part of an Operations Hazard and Risk analysis. If a wayside ATC failure affects Yard mode, RM mode is the most appropriate mode for further train movement, protected by procedure. If the on-board ATC fails, then the Train Operator must select ATC Bypass for further train movement, protected by procedure.</p>

MODE OF OPERATION	ATO OR MANUAL OPERATION	MAX TRAIN SPEED	ENFORCED BY	NOTES
Bypass	N/A	FRA limited speed is 59 MPH per 49CFR236 subpart I.	<p>Rolling Stock propulsion and possibly braking subsystems.</p> <p>This is a mode NOT enforced by ATC. In this mode, ATC is in Bypass mode and is not connected to the rolling stock equipment.</p> <p>Safe operation of trains is maintained by home signal indications, by rules and procedures, by regular training and refresh.</p> <p>The maximum speed limit of 59 MPH will be enforced by the rolling stock propulsion subsystem.</p>	<p>A degraded mode.</p> <p>This mode is used if the on-board ATC fails.</p> <p>Shall require a separate Bypass switch that will be sealed normally in the ATC (not Bypassed) position.</p> <p>No secondary enforcement system is required other than a maximum speed supervised by the Rolling Stock propulsion subsystem.</p>

6.3.6 Automatic Train Operation

In ATO mode, an on-board ATO subsystem that controls the operation of rolling stock propulsion and brakes, to start a train at a station, accelerate it, regulate its speed to below the speed limit, move the train between scheduled station stops, and brake the train to a precision stop at the next station, all subject to Movement Authority limits set by the ATP subsystem. ATO mode is extensively used in transit systems worldwide, but has had limited use on main line and high speed railroad lines. ATO is now starting to be deployed on passenger main line tracks including high speed operations outside the U.S.

ATO operation shall be incorporated into the ATC system design for all phases of station to station running on the main lines and for exit and entry to yards including;

- acceleration from station stops
- cruising at recommended speeds determined automatically by the schedule regulation function of the ATS subsystem, or manually set by console dispatchers through the ATS workstations
- stopping and restarting for ATC enforced stops defined by movement authorities
- Exit from yard transition tracks within yards to the main line
- Entry to yard transition tracks from the main line
- station stopping

ATO requirements shall therefore be incorporated in the interfaces with rolling stock and other impacted subsystems. The decision to employ ATO and possible sub-modes of ATO lies with the Operator.

6.3.7 Bi-Directional Signaling

Although normal passenger train operations only require one track in each direction, it is intended that bi directional capability shall be incorporated into the ATC design. With the use of microprocessor interlocking and logic equipment, the cost of bidirectional signaling is marginal, resulting only from possible additional wayside signals and marker boards (see later section on wayside signals). In the event of a subsystem failure, trains will be routed onto the same track to bypass a failure on the other track. Traffic locking shall be used to allow safe following moves and prevent routes being cleared into tracks in opposing directions until the section between interlockings is clear. Trains operating in either direction on the mainline tracks equipped for bidirectional operations shall utilize full ATC functions including PTC and possibly ATO for station stopping.

6.3.8 Interlockings

Interlocking functions shall be achieved through the deployment of microprocessor technology. Conventional relays shall be used at a minimum. Interlocking requirements shall be specified including route clearing, approach locking, detector locking, route locking, traffic locking and other functions. Approach locking shall be provided as the intermediate interlockings between stations will normally be fletted. Interlocking equipment shall be interfaced with other ATC subsystems to send movement authorities to trains that shall ensure safe movement through interlockings. Wayside signals shall be located at interlockings and shall indicate the status of routes at their entrances however these signals shall not be the primary indication of route status; this shall be achieved through the Train Operator's display in the cab.

6.3.9 Track Circuits

The use of track circuits is driven by the need to comply with FRA requirements related to the detection of broken rails. The ATC system shall require a track circuit based system; in the event of a broken rail, the system shall assume a train is present and prevent a following train from entering the apparently occupied block. Further movement will be under procedure allowing the Train Operator to observe the track ahead to determine if a broken rail does exist.

6.3.10 Wayside Signals and Support to Fall Back Operations

The ATC system design will assume that wayside signals shall be required at the following locations;

- At the entrance to interlocking routes (home signals)
- In Yards

The prime use for signals on the main line is to support safe train operation when the primary ATC system is not available and when movement authorities cannot be received and enforced by the on-board ATC subsystem. Home signals shall be provided on main lines at the entrance to interlocking routes only and intermediate signals will not be provided. At high speeds, signals will not be visible in a useful way to the Train Operator who must follow the cab signal indications or allow the train to operate in ATO. During failures of the primary ATC system, the maximum train speed will be limited to 59 mph which is the current limit incorporated into the 236CFR subpart I; Maximum speed when operating with failed PTC system. In addition, under present rules a train with an ATC failure that occurs while the train is located between interlockings must be operated at Restricted Speed until it passes a wayside signal that indicates that there is no broken rail in the signal clock ahead.

A headway requirement to be supported by intermediate wayside signals shall not be specified.

Wayside dwarf type signals are favored as they minimize installation cost and reduce life cycle maintenance cost due to easier access for inspection and repair. The final decision on signal type shall depend upon the agreed maximum speed when operating in degraded mode. Subpart I specifies a speed of 59 mph or less for passenger trains operating in degraded mode without PTC functions.

It is currently assumed that speed enforcement in degraded mode will be achieved by means of a speed governor function incorporated in the rolling stock propulsion subsystem. This governor shall be activated by the ATC cutout switch in the operating cab. If the train speed exceeds the defined maximum (say 59 MPH) then the propulsion subsystem will cut power to the motors and an audible and visual alarm will sound in the cab.

6.3.11 Switch Machines

Power switch machines shall be provided on all switches and on moveable point frogs on the main line and in yards (see later in this section). The design team will determine a number of switch machines for each type of switch (which can be up to 8 machines per switch end for the highest speed turnouts) for the purposes of preliminary engineering and cost estimating. The actual number of machines needed to meet the functionality and RAMS performance requirements for the project will be detailed to ensure consistency between line segments to ensure a uniform maintenance approach on all parts of the CHSTP system.

Yard switch machines shall be of a different type from mainline, see the section on Yard Signaling later in this document.

Switches at high elevations shall be equipped with snow melters powered from the OCS.

6.3.12 Impedance Bonds

Impedance bonds shall be required at traction power facilities, track circuit boundaries and possibly other locations including insulated joint locations at interlockings, and at intermediate locations where ground connections need to be made to the OCS static wire. Grounding may also be required at impedance bonds at track circuit boundaries. Engineering must be done to determine where these ground connections can be made to ensure correct track circuit operation under normal conditions; to ensure that touch potential criteria are met. Engineering shall be conducted to ensure that the track circuits will correctly detect a broken rail. The Final Designer will coordinate with the traction power engineers in developing the track circuit and impedance bond locations.

6.3.13 Wayside ATC Equipment Housings

ATC equipment shall require wayside housings that shall vary depending on the location. The larger, bungalow styles shall need to be located at interlockings; smaller wayside cases shall be required adjacent to track circuit boundaries. Other locations may also require wayside housings including interface locations with event sensors including roadway underpasses, seismic detectors, wind speed measurement, etc.

Allowances shall be made in ATC houses to accommodate communications equipment that is associated with the train control system operation. Such equipment includes fiber drop and network equipment as well as data radios.

Site requirements for ATC elements are covered in Technical Memorandum 3.3.2; Train Control Site Requirements.

6.3.14 Wayside ATC Power Supplies

Power sources for ATC wayside equipment will normally be straightforward at stations and interlockings where utility feeds are assumed. Other locations such as track circuit boundaries where they occur every mile or so in remote, desert, and mountainous regions are likely to be problematical and/or expensive and alternatives to utility feeds are being considered. Alternatives include dedicated signal power feeds from adjacent ATC sites that have utility power feeds, drops from the OCS, solar panels, and wind turbines. In all cases these sources shall be supplemented with local batteries. Power supplies for ATC equipment in the field is addressed in Technical Memorandum 3.3.3; Train Control Wayside Location Power Supply Options.

6.3.15 Remote Control and Supervision System

The remote control and supervision strategy will have an impact on the specification for the Automatic Train Supervision (ATS) (Office Subsystem) functional set of the ATC. At present it is assumed that the ATS functionality, subsystem performance, and hardware requirements shall be specified as part of the ATC system.

Many of the functions of ATS including automatic dispatching of trains and routing through interlockings and terminals shall be accomplished automatically with manual intervention only required in the event of system failure or unplanned occurrences.

It is currently assumed that the ATS prime location will be in the main Operations Control Center (OCC) and that there will be remote workstations at other locations (Regional Control Center(s) (RCCs)) that will allow dispatching in certain regions, particularly the shared and common corridors to be done relatively locally. In the event of major incidents and failures, each RCC shall be capable of taking control of the whole CHSTP system.

Availability considerations may also require that the ATS core equipment including communications and database servers may need to be located in both the OCC, Regional Centers, and possibly other sites with options for cold, warm, and hot standby of the back-up systems given further consideration. This shall ensure that in the event of a major incident that knocks out the OCC (earthquake, sabotage/terrorist action, major fire, etc.) centralized Supervision and Dispatching can continue with little or no interruption to operations. In emergencies, the control of interlockings can be taken from a Regional Center or a station control room.

Current planning has identified that dispatching of the peninsula corridor will require a regional center to handle high speed and Caltrain services between San Jose and San Francisco. This Regional center would be staffed 24/7 and could be considered a location that could assume supervision and control of the full high speed network during a major incident.

A further level of degraded operation can be achieved by means of local control panels (connected to the ATC houses) in adjacent station control rooms. Although local control facilities shall be specified for the ATC in the stations, the reliability/availability of the communications subsystem makes the loss of control from the ATS highly unlikely.

Consideration will also be given to specifying a form of field-fallback mode for the remote interlockings in which they will revert to normal routes being called and fleeted in the event of a loss of communications with the ATS. A local control panel in the interlocking control house shall also be provided for local control in emergencies and for maintenance testing needs.

For control of Yard movements, each yard shall have a local tower with controls and displays allowing Yard supervisors to route trains within the Yard and shops with local control panels or workstations. Handover of trains between the main lines and the yard tracks shall be accomplished with an interface to the ATS system or ATS workstations which can be located within the Yard towers. See next section on Yard signaling.

6.3.16 Yard Signaling

The Yards shall require a signal system to operate switches and control movements of trains in the yard itself and for transitions between the Yard and the mainline. Currently it is assumed that there will be power switch machines, dwarf type signals, and power-operated derails at the wayside. Switch machines shall be of a common yard type and not main line machines. Yard machines are cheaper and can provide a trailable feature which lowers the risk of damage to equipment and of derailment if a train should trail a switch set in the wrong position for the move.

Enforcement of signals and protection of trains and workers in the Yards shall be accomplished by means of a transponder system or equivalent. There shall need to be a level of safe interlocking between signals, derails, and switches although the level of safety in a Yard system is typically less than specified for the mainline. Trains will operate in some form of Yard mode (see the Operating Modes table above) and yard signals displaying stop indications shall be enforced.

Control of yard signals, derails, and switches in yards shall be from local Yard towers and not from the OCC or RCCs. Maximum speed enforcement in the Yards shall be by the on-board ATC subsystem. In order to be exempt from installing PTC in the yard the speed limit within the yard cannot exceed 20 mph (49CFR236.1019(b)(1)).

Access and exit from shop tracks into the Yard proper shall be protected by means of power-operated derails.

The transition process between depot and mainline shall entail a transition track in which trains will be routed both when entering and exiting each Yard. Transition from Yard to ATC mode of operation and vice versa shall occur automatically. Trains departing the Yard to the Main Line shall undergo an ATC systems check before being allowed to be routed and a Movement Authority or valid speed and destination code sent to the train. The transition tracks must be

treated by Operations and maintenance personnel as main line track as trains shall be capable of full ATC operation, including ATO. ATO shall be possible leaving the transition track for the main line and when entering the transition track from the main line. ATO shall not be available for movements between the transition track and the Yard in either direction.

6.3.17 Responses to Detection Devices

It is anticipated that there will be a wide variety of detectors placed on and around the system. The devices may include, but not be limited to the detection of the following events;

- Earthquake
- Excessive wind speed
- High water levels
- Excessive rainfall
- Road and Rail underpass bridge strike
- Landslide and rock fall
- Intrusion at trackside and in tunnels
- Intrusion from overhead bridges and at tunnel portals
- Intrusion at stations

Each type of detection will be evaluated for the level of risk each hazard can pose to the operation and the interface to the ATC system and what kind of response is required of the ATC determined. The different types of response can include;

- Switch automatically from ATO to manual operation (note if the ATO function is designed around a “hands off” approach this will typically invoke a service brake until the Operator takes the controller).
- Stop the train immediately with a service brake
- Stop the train immediately with a controlled emergency brake
- Block an affected section of track and the on-board ATC determines the level of brake needed to avoid entering the blocked track or to stop the train if it is already entering or in the affected track section.

In the case of intrusions at stations the choice will be between automatic sensors or customer/staff operated alarms.

Consideration will be given to the types of responses required for different levels of intrusion.

Dragging Equipment Detectors are to be given further consideration for adding to the list. If not necessary on the HSR tracks themselves, strategic DEDs may be required where possible freight or other operators’ trains (e.g. Caltrain) may approach but prior to them actually running on HSR tracks. High load detectors to protect the overhead contact system from freight trains may also be needed.

6.3.18 ATC Integration

Close coordination with Rolling Stock, Communications, and Operations is required during the development of the ATC criteria and specifications to ensure an integrated system. Certain ATC elements shall need to reside in specific portions of the train control system. Some functions shall be achieved by having distributed portions of them residing in more than one subsystem, or even amongst other systems. Integration work must be done with the rolling stock team to ensure that sufficient space and power are provided for and that details relating to certain

components, for example particular types of tachometer (axle end for example) are not precluded from the design due to details of body and truck design nor rolling stock maintenance requirements

The location of the subsystem or module in which certain ATC functions reside is dependent upon the architecture proposed by the ATC Supplier. To the extent possible, the specifications shall allow flexibility to the supplier to propose the most cost-effective solution that provides the required overall functionality and performance, especially safety and reliability, of the system.

6.3.19 Determination of Position and Speed

The wayside system shall use track circuit occupancy to determine train position. The on-board system requires a much higher resolution of speed and position so the train can:

- Travel through a block as fast as safely possible
- Be operated in accordance with civil speed restrictions that may not be limited to track circuit boundaries
- Stop before it moves past its Movement Authority limit.

An accurate and reliable determination of position and speed is one of the most critical functions of a modern train control system. In order to do this ensuring fail-safe characteristics as well as high availability, it is typically done with a combination of devices and techniques, including tachometers, inertial sensors, GPS, and transponders or balises (mounted between the rails on the track).

Wayside equipment in the form of track circuits indicates the position of a particular train on the track which is used to fulfill the interlocking functions and to protect a specific train from following trains.

Target points shall be established as part of a Movement Authority for a specific train which defines the maximum limit of a train's movement along the track and defines the maximum speeds that the train is allowed to attain between its current position and its target point.

- Each train shall receive its Movement Authority from the wayside based upon factors including the status of routes through interlockings, the position of switches, occupancy of track circuits, and other elements of the wayside signal system and relate them to the on-board database.
- On-board databases shall allow for updates from the central control system for the temporary modification of database elements including speed restrictions.
- The on-board ATC subsystem shall determine its position in relation to the database and compare its actual speed with the allowed speed at their current position on the track.
- The Train Operator's display shall provide sufficient information to allow the operator to modulate the throttle and brake to allow the train to travel as close to the speed limits without unnecessary automatic interventions for impending or actual overspeed.

Speed and position sensors shall be based on proven products and also be combined in such a way that the information derived by the train is truly vital. This may require a diverse means of obtaining data from which speed and position can be determined.

Although rolling stock supplied tachometers may be used by the ATC system for non-vital functions, the primary vital function of train position and speed determination shall use sensors provided and installed by the ATC system supplier.

6.3.20 Hardware Requirements for Various Subsystems

The following specific hardware requirements have been identified;

- Tachometers; Mounted on the axle ends or on gearboxes. Similar devices are required by the train propulsion and brake systems for slip and slide control. These devices translate pulses as the axles rotate into distance traveled, and are subject to errors from wheel wear, wheel slip, and wheel slide. Such errors occur despite the wheel slip and slide protection provided in the propulsion and braking systems on the rolling stock. Although the train control system can use data derived from multi channel devices provided for the propulsion and braking subsystems on the train, the typical approach, and one that better assures availability and safety-criticality, is for the signal system supplier to provide their own dedicated tachometers in a location provided by the rolling stock supplier in a detailed interface definition.
- Transponders; Also called balises, are mounted between the rails and provide a set of fixed or variable data to the train when an underside antenna on the train passes over them. This data is used to correct any accumulating positioning error in the on-board subsystem, generally due to slip and slide between the wheels and the rails. The train control system continuously assesses the worst case for error accumulation and takes account of it in the safety components of the system. The Eurobalise is designed specifically to work reliably at 200+ mph to ensure a minimum quantity of data can be received by the train.
- Other devices; GPS is being used by the North American PTC system in conjunction with tachometers. The use of GPS as a prime component of position determination in a vital signal system will not be considered. In addition to vital system considerations, there are potential problems for availability, particularly when a train is operating through tunnels or in city areas with tall buildings that can block satellite reception. Other devices include inertial navigation systems which although proven in aerospace applications, have little experience on railroads. Such devices can be used for dead reckoning and incrementally summing accelerations in the three axes to determine distance and direction moved. They are subject to errors by train suspension effects and accelerations caused by discontinuities in the track.

Both speed and position can be determined from some of the same devices as described above. Tachometers, inertial devices, and GPS can determine speed very accurately when used in combination.

Position determination using GPS would likely be in combination with tachometers and other on-board devices. Some development will be required however for a supplier to demonstrate in the system safety analysis that the specified criteria for reliability, availability, and safety can be met by the incorporation of GPS and other integrated devices. GPS receivers will likely be used to determine time for the system to ensure that safety-critical data received from the wayside and central office is current.

Unproven technology in the high speed environment will not be considered.

6.3.21 Types of Data Transmission from Transponders

Transponders (or balises) can be of two basic types; the first contains fixed data which is transmitted to trains as they pass over the location with no connection to any other ATC element. The second contains variable or fixed and variable data whereby a connection to another ATC system element can alter the data transmitted (for example different speed limits can be transmitted if the switch ahead is in the normal or reverse position).

- The fixed data can simply be a unique location identification which the train compares to its database and corrects any error based on a calculation of its position determined from on-board equipment (e.g. tachometers).

- Fixed data including speed limits can also be transmitted to the train. It is envisaged that such data will be contained within the on-board database and transponders shall not be required to upload this information.
- Variable data can include the status of the railway in front of the train.
- Transponders also provide an absolute confirmation of the train's position which can be used as a diverse confirmation of position and therefore support the safety case for the system and as a means of positive confirmation of position if the train is operated under procedure through a switch with unknown status during failures. This is preferred to a manual input confirmation as it enhances safety during failure conditions.

Transponder-only transmission to trains provides only for an intermittent ATC system and this type of system has performance and functional constraints when compared to a continuous communications type ATC system. It is therefore envisaged that the ATC system shall receive Movement Authority data either through a radio link (such as with ERTMS) with the wayside equipment houses and cases or through a digitally encoded track circuit transmission through the running rails (TVM430 etc).

Transponders shall therefore be required for both radio and coded track circuit types of system to provide the position error correction function for an on-board speed and distance traveled determination subsystem.

6.3.22 Location of On-Board ATC Equipment

A number of items of train control system apparatus shall be mounted on the rolling stock. These include the displays for the Train Operator, the train control logic controller, the train control communications equipment, the location determination subsystem (tachometer, GPS, inertial navigation, transponder reader antennas, etc.), data radios, and antennas for GPS and data radios.

Much of this equipment is unique to specific ATC suppliers and would normally be supplied by them as opposed to the rolling stock supplier.

The CHSTP Systems team will coordinate between the ATC, communications, rolling stock, and operations personnel to discuss the different types of equipment required and identify sufficient provisions that must be accounted for in the rolling stock design to allow for the following;

- physical space requirements
- mounting provisions
- cables and cableways to connect the equipment
- termination panels
- power and ventilation needs
- other considerations including non-metallic panels around radio and GPS antennas

The requirements must support multiple, applicable vendor equipment together with defined functionality allocation (between train control and train subsystems),

6.3.23 ATC Safety Requirements

The ATC system and subsystem safety criteria shall set thresholds for ATC system safety that shall be compatible with the overall CHSTP system safety criteria.

Further consideration will be given to acceptable methods for achieving error free code. Several train control projects have suffered delays on recent years even with established systems that

were proposed not being able to meet specified standards. Appropriate formal methods will be reviewed and specified if appropriate.

In the achievement of error free code, the approach of specifying proven systems with a minimum of new or changed functions will minimize the risk to schedule and budget posed by software development risks.

The ATC safety requirements shall also include the incorporation into the system design of a set of safe braking criteria that will be described as part of a model. This safe braking model shall define the necessary criteria that the ATC and Rolling Stock systems must meet in order to satisfy the safe separation of trains, enforcement of home signals, and enforcement of speed limits.

The system design shall include the ability of the ATC subsystem to command both a controlled emergency brake in which wheel slide protection is active, and an absolute emergency brake in which wheel slide protection is cut out.

6.3.24 Reliability, Availability, and Maintainability (RAM) of the ATC System

The ATC system and subsystem safety criteria shall set thresholds for ATC system RAM that shall be compatible with the overall CHSTP system RAM criteria.

Extremely high availability shall be specified to avoid delays that might occur from system and subsystem failures. Different degrees of redundancy may be appropriate for different portions of the system in order to achieve the availability targets but at the same time minimize the failure rate and the mean time to repair.

6.3.25 Data Radio Requirements

A high speed, high availability performance shall be specified, with comprehensive and likely overlapping, coverage throughout all main line and yard tracks.

Radio alternatives will be investigated by the Systems team for applicability (performance, coverage, availability, etc.) of the frequencies and bandwidth. Existing and emerging public standard systems will be considered.

6.3.26 Interfaces

The ATC system shall interface to the following subsystems;

6.3.26.1 Rolling Stock

If the Rolling Stock is to be procured separately to the core systems for CHSTP, a significant amount of detail shall be agreed such that the Rolling Stock side of the interface can be included in the scope of the procurement.

6.3.26.2 Communications

Interfaces between the ATC subsystem and the Communications subsystem are also extensive. In the event that an ERTMS train control system is selected, data and voice radio communications shall be integral with the overall ATC subsystem.

6.3.26.3 Traction Power

The bonding and grounding scheme for ATC shall be compatible with the needs of the traction power subsystem.

6.3.26.4 OCS

It is anticipated that the ATC subsystem may be required to implement two functions;

- On-board switching commands to the rolling stock subsystem to allow isolation between section gaps as the train traverses the gap; this is likely a database function only where the section gaps are identified in the on-board database
- Prevention of trains entering sections of the line where the OCS has been de-energized; this shall require an interface between the OCS energized indication and the ATC. This could be done at the OCC level with an interface between ATS and SCADA or at a local level. Modified movement authorities would be transmitted to the on-board ATC and a stop enforced.

6.3.26.5 Track

The details of the track layout including switch configurations, gradient, curvature, etc. must be included in the ATC database. There shall also be physical interfaces between the switch machines and the switches themselves and between the track and ATC transponders where the latter must be securely fixed to the track and maintained within strict tolerances.

In the Yards, derails and transponders (if used for yard signal enforcement) shall also be fixed to the track.

6.3.26.6 Infrastructure

The ATC subsystem shall interface with infrastructure as a result of the need to install equipment houses, cases and other elements such as signals along the right of way and comply with clearance requirements and access to the various ATC facilities. Basic footprint, equipment size, and access needs have been provided to the infrastructure group.

Special considerations shall be given to tunnel portals for the need to house ATC equipment in buildings and other structures at these locations.

6.3.26.7 System Time

The ATC subsystem shall derive its standard time through an interface with GPS.

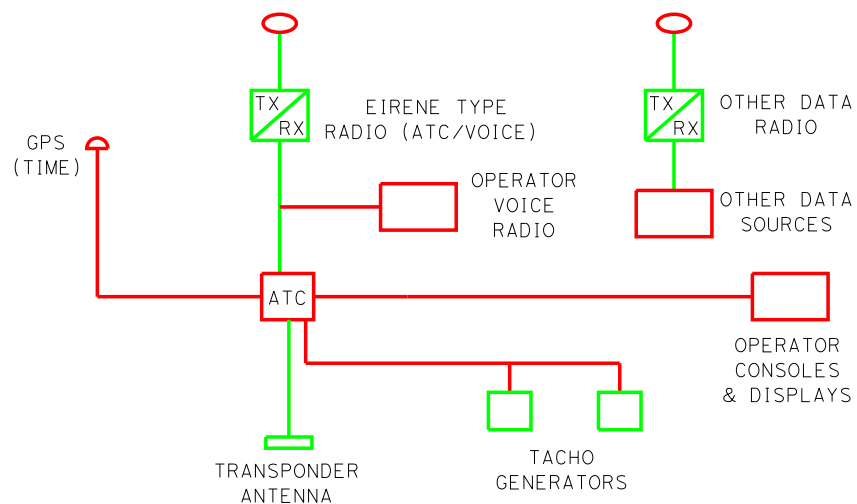

LEGEND:

- OCC OPERATIONS CONTROL CENTER
- TPF TRACTION POWER FACILITY
- X WAYSIDE ATC EQUIPMENT ROOM
- FIBER BACKBONE
- +— INSULATED RAIL JOINT
- +— TRANSPOUNDER (BALISE)
- +— WAYSIDE SIGNAL (MAINLINE)
- +— WAYSIDE SIGNAL (YARD)
- +— POWER OPERATED DERAIL/OTHER ENFORCEMENT DEVICE

ATC/DATA/VOICE COMMUNICATIONS OPTIONS

- - - - - **GSM-R:** BANDWIDTH SEARCH IN PROGRESS
WILL SUPPORT ATC, VOICE OTHER DATA
- - - - - **IEEE 802.16M:** DATA COMMUNICATIONS (STD. BY 2013)
≈ 2.4 GHZ TO 2.9 GHZ OR 5.4 GHZ TO 5.9 GHZ
- - - - - **VOICE RADIO:** TRAIN TO WAYSIDE ANTENNA
≈ 450 MHZ RANGE - SUBJECT TO NARROW BANDING
- 22 NARROW BAND CHANNELS AVAILABLE
- ALSO REQUIRES 160 MHZ IN SHARED CORRIDORS
- 220 MHZ MAYBE REQUIRED FOR PTC INTEROPERABILITY IN SHARED/Common CORRIDORS

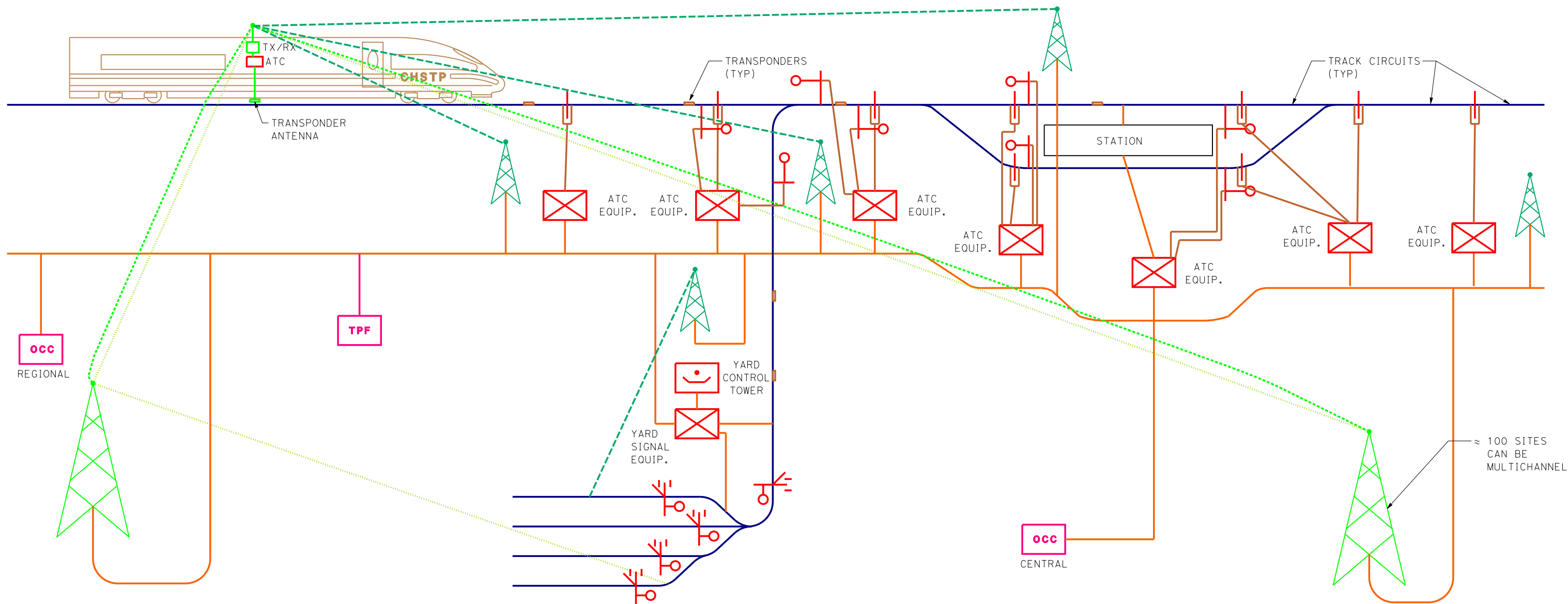

6/8/2010 4:23:59 PM T:\13259B Calif High Speed Rail\CADD\Directive Drawings\3.3.1\Working\3.3.1-A.dgn David

REV	DATE	BY	CHK	APP	DESCRIPTION

DESIGNED BY
E. MORTLOCK
DRAWN BY
E. MORTLOCK
CHECKED BY
H. GLICKENSTEIN
IN CHARGE
R. SCHMEDES
DATE
06/08/10



CALIFORNIA HIGH-SPEED TRAIN PROJECT

COMMUNICATIONS AND ATC SCHEMATIC CONCEPT
(ERTMS EIRENE TYPE SYSTEMS, VOICE AND OTHER DATA)

CONTRACT NO.	13259
DRAWING NO.	TM 3.3.1-A
SCALE	NO SCALE
SHEET NO.	

6/8/2010 4:24:32 PM T:\13259B Calif High Speed Rail\CADD\Directive Drawings\3.3.1\Working\3.3.1-B.dgn

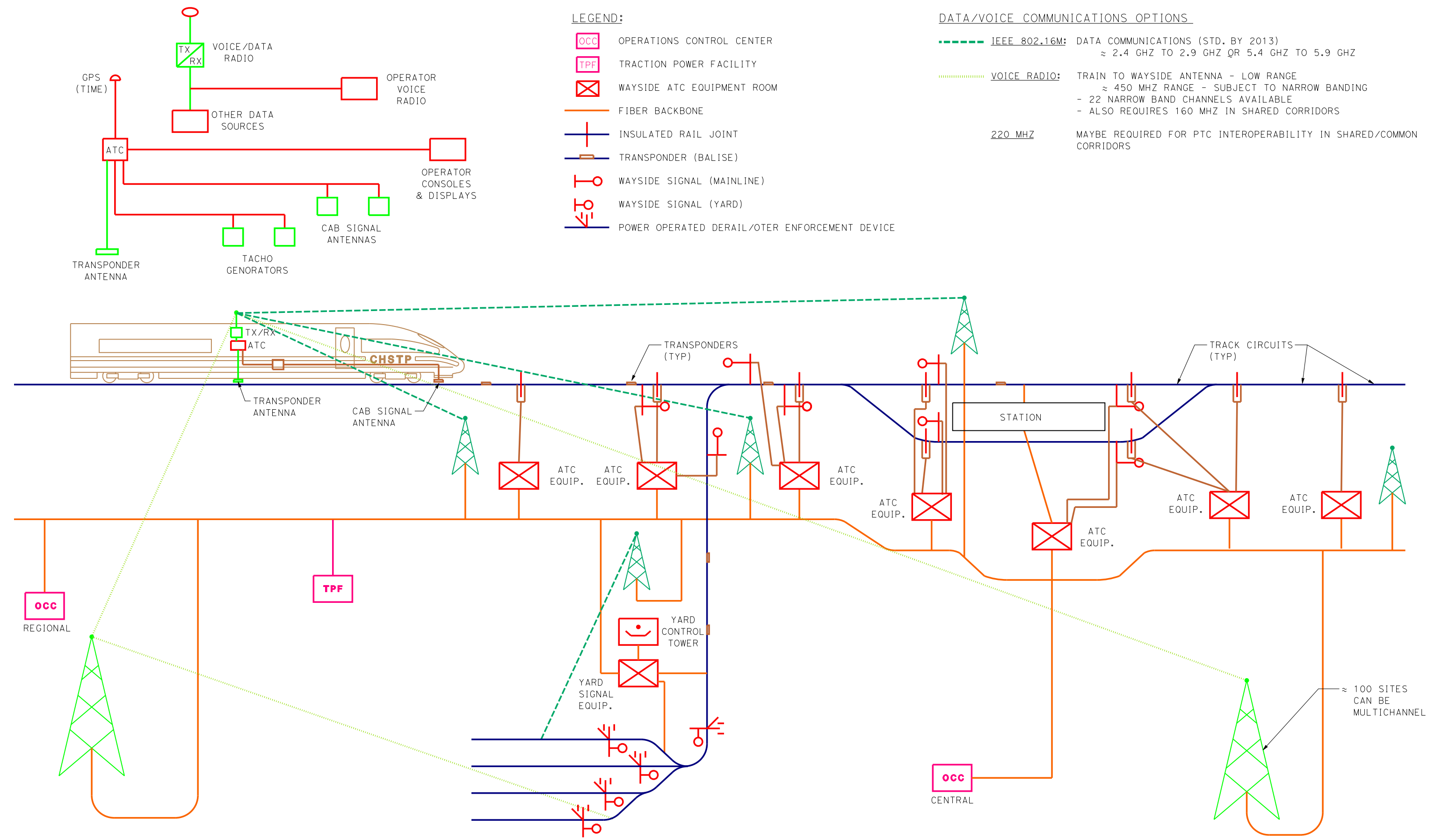

DESIGNED BY
E. MORTLOCK
DRAWN BY
D. SOLTERO
CHECKED BY
H. GLICKENSTEIN
IN CHARGE
R. SCHMEDES
DATE
06/08/10



CALIFORNIA HIGH-SPEED TRAIN PROJECT
COMMUNICATIONS AND ATC SCHEMATIC CONCEPT (CAB SIGNAL SYSTEM, VOICE AND OTHER DATA)

CONTRACT NO.
13259
DRAWING NO.
TM 3.3.1-B
SCALE
NO SCALE
SHEET NO.